

FISA DE MONTAJ

Lv2. SUSPENDAT CU O USA

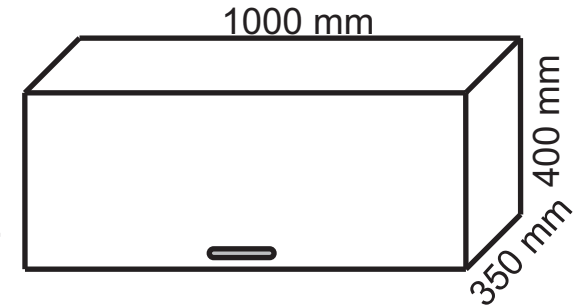

PASUL 1:

Se prind cele doua laterale (1) si (2) de capacul (3) in gaurile existente, folosind eurosuruburi si cheia imbus. Apoi se aseaza spatele (5) din PFL 3mm in canalele existente pe laterale si capac.

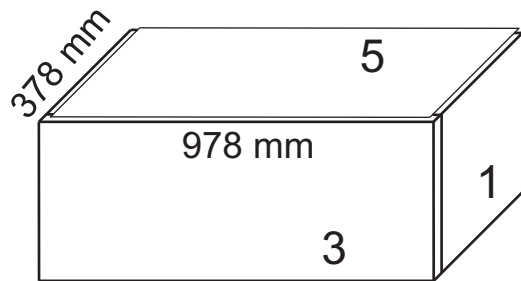

PASUL 2:

Se prinde apoi si capacul (4) de laterale si tot prin eurosuruburi.
Se prinde manerul de usa (7) folosind suruburile M4x20.

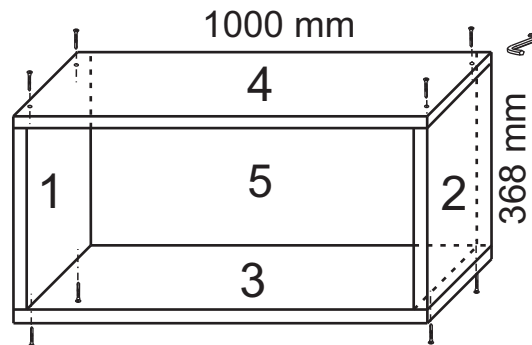





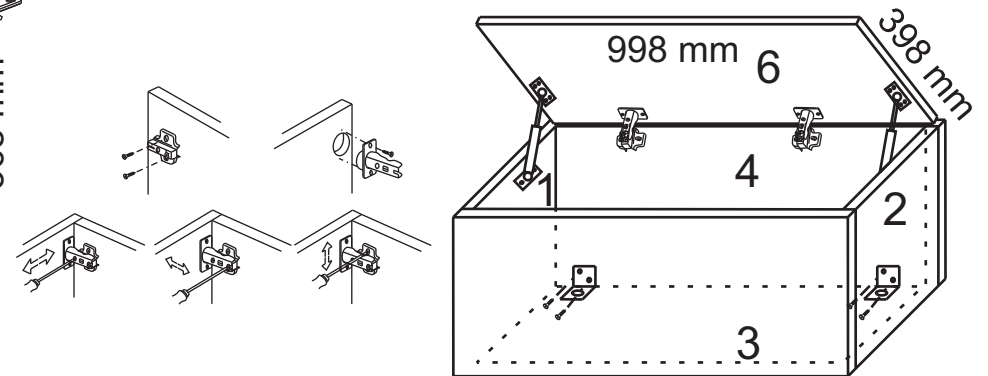

PASUL 3:

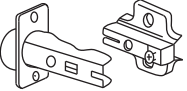
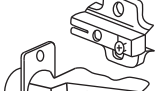
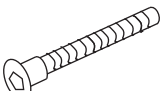
Se prind balamalele de usa si contrele de capacul superior (4), se realizeaza ansamblul balama-contrabalama reglandu-se usa, iar apoi se prind pistoanele de usa si laterale (1,2) conform instructiunilor de montare ale pistonului.
Se prind coltarii agatatori de capacul (4) prin holsuruburi 3.5x16 apoi se fixeaza corpul de perete.

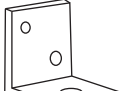

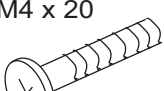
ACCESORII

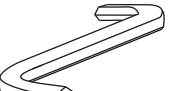
| Balama aplicate | Balama semiaplicata | Eurosurub | Holsurub | Coltar agatator | Tinte | Maner | Surub | Piston gaz | Cheie imbus |
|---|---|---|---|--|---|---|---|---|---|
|  |  |  |  |  |  |  |  |  |  |
| Buc. x 2 | x 0 | x 8 | 3,5 x 16 x 12 | x 2 | x 0 | x 1 | M4 x 20 x 2 | x 2 | x 1 |