

UPUTSTVO ZA MONTIRANJE  
ASSEMBLING INSTRUCTION  
MONTAGEANLEITUNG  
INSTRUCTIONS D'ASSEMBLAGE  
INSTRUCCIONES DE MONTAJE

ISTRUZIONI PER L'INSTALLAZIONE  
ИНСТРУКЦИЯ ПО МОНТАЖУ  
MONTÁŽNÍ NÁVOD  
ΟΔΗΓΙΕΣ ΣΥΝΑΡΜΟΛΟΓΗΣΗΣ  
INSTRUCȚIUNI DE MONTAJ

ИНСТРУКЦИЯ ЗА МОНТАЖ  
SZERELÉSI UTASÍTÁS  
NAVODILA ZA MONTAŽO  
UPUTE ZA MONTAŽU  
UPUTSTVO ZA MONTIRANJE

УПАТСТВО ЗА МОНТИРАЊЕ  
UDHËZIMET PËR MONTIM  
INSTRUKCJA MONTAŻU

# VICTORIA 200

**CODE: UP 00354**  
**Version: 03 - 23032018**

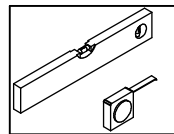
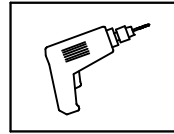
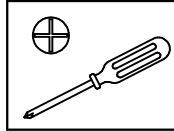
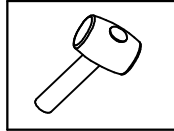
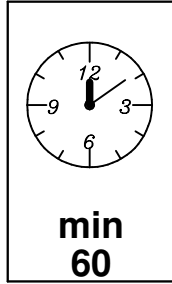
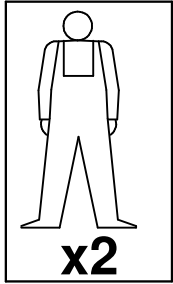

**RS** ME PRE POČETKA MONTIRANJA OBAVEZNO PROČITAJTE UPUTSTVO ZA MONTAŽU / **UK** BEFORE STARTING, REFER TO THE ASSEMBLING ADVICE IN ANNEX / **DE AT CH** VOR DER MONTAGE BITTE BEILIEGENDE ANWEISUNGEN LESEN / **FR CH** AVANT LE DÉBUT DE L'ASSEMBLAGE, S'IL VOUS PLAÎT, LISEZ L'INSTRUCTION D'ASSEMBLAGE / **ES** ANTES DE EMPEZAR EL MONTAJE, LEER CUIDADOSAMENTE LAS INSTRUCCIONES DEL ANEXO / **IT CH** PRIMA DI INIZIARE L'INSTALLAZIONE SI RACCOMANDA DI LEGGERE LE ISTRUZIONI DI INSTALLAZIONE / **RUS** ДО НАЧАЛА МОНТАЖА ОЗНАКОМЬТЕСЬ С ИНСТРУКЦИЕЙ / **CZ** SEZNAMTE SE S NÁVODEM PŘED MONTÁŽÍ NÁBYTKU / **EL** ΠΡΙΝ ΞΕΚΙΝΗΣΕΤΕ ΤΗ ΣΥΝΑΡΜΟΛΟΓΗΣΗ, ΟΠΩΣΔΗΠΟΤΕ ΔΙΑΒΑΣΤΕ ΤΙΣ ΟΔΗΓΙΕΣ ΣΥΝΑΡΜΟΛΟΓΗΣΗΣ / **RO** ÎNAINTE DE ÎNCERPEREA MONTAJULUI ESTE OBLIGATORIE CĂTIREA INSTRUCȚIUNILOR / **BG** ПРЕДИ МОНТИРАНЕ НЕ ЗАБРАВЯЙТЕ ДА СЪ ЧЕТЕ ИНСТРУКЦИИ ЗА МОНТАЖ / **HU** SZERELÉS ELŐTT OKVETLENŰL OLVASSA EL A HASZNÁLATI UTASÍTÁST / **SL** PRED ZAČETKOM MONTAŽE OBVEZNO PREBERITE NAVODILA / **HR** PRIJE MONTAŽE UPOZNATI SE SA UPUTSTVOM / **BIH** PRE POČETKA MONTIRANJA OBAVEZNO PROČITAJTE UPUTSTVO ZA MONTAŽU / **MK** ПРЕД ПОЧЕТОК НА МОНТИРАЊЕ ЗАДОЛЖИТЕЛНО ДА СЕ ПРОЧИТА УПАТСТВОТО ЗА МОНТИРАЊЕ / **AL** PARA FILLIMIT TË MONTIMIT LEXONI PATJETËR UDHËZIMIN PËR MONTIM / **PL** PRZED ROZPOCZĘCIEM MONTAŻU PROSZĘ ZAPOZNAĆ SIĘ Z INSTRUKCJĄ

**var. 1**

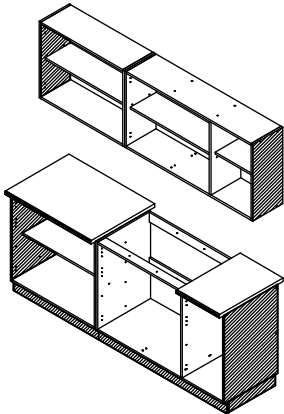

**var. 2**

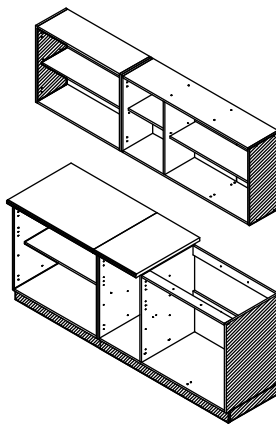

**var. 3**

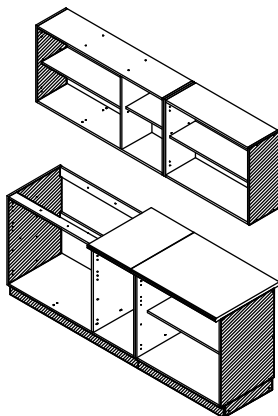

**var. 4**

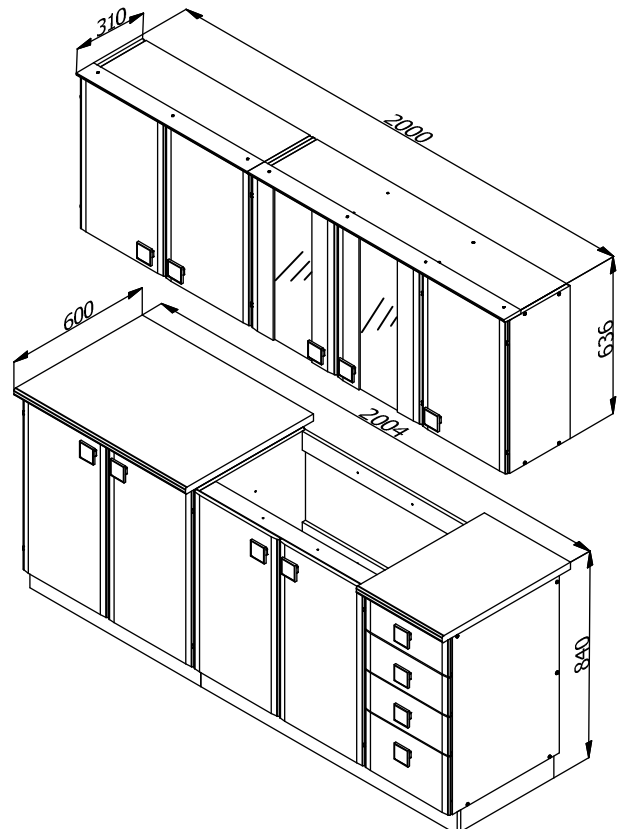
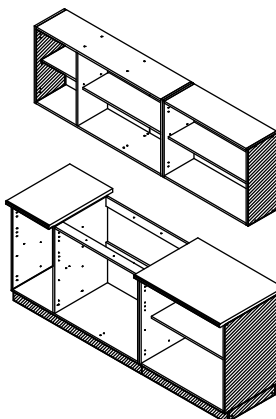



<p><b>RS ME</b></p> <p>1. Montažu obavljati na čistoj i mekoj podlozi (karton, tkanina...)</p> <p>2. Da bi izbegli oštećenja elemenata pridržavati se datih instrukcija.</p> <p>3. Prilikom prijave reklamacije koristiti date oznake elemenata.</p>	<p><b>FR CH</b></p> <p>1. Effectuer l'assemblage sur une surface propre et douce (carton, tissu...)</p> <p>2. Afin d'éviter l'endommagement des éléments, respectez les instructions données.</p> <p>3. Lors de l'application de réclamation, utiliser les désignations données des éléments.</p>
<p><b>DE AT CH</b></p> <p>1. Die Montage soll auf sauberer, weicher Fläche durchgeführt werden (Karton, Stoff)</p> <p>2. Um die Beschädigung der Elemente zu vermeiden, befolgen Sie bitte die angegebenen Instruktionen</p> <p>3. Bei Reklamationsmeldungen benutzen Sie bitte die angegebenen Kennzeichen der Elemente</p>	<p><b>UK</b></p> <p>1. Assembly of the product should be done on a clean and soft surface (cardboard, fabric)</p> <p>2. To prevent damage of the product, it is necessary to adhere to the assembly instructions</p> <p>3. While reporting defective products, please quote codes in manual</p>
<p><b>ES</b></p> <p>1. Realizar el montaje sobre una superficie limpia y suave (cartón, paño)</p> <p>2. Para evitar daños del producto, atenderse a las instrucciones de montaje</p> <p>3. Para reportar productos defectuosos, refiérase por favor a los códigos del manual</p>	<p><b>IT CH</b></p> <p>1. Eseguire l'installazione su una base morbida (cartone, tessuto).</p> <p>2. Seguire le istruzioni per evitare di causare danni agli elementi.</p> <p>3. In caso della presentazione di reclamo si utilizzano relative indicazioni degli elementi.</p>
<p><b>RO</b></p> <p>1. Montarea se efectueaza pe o suprafata moale și curată (carton, material..)</p> <p>2. Respectați instrucțiunile pentru a evita deteriorarea pieselor</p> <p>3. La transmiterea reclamațiilor a se folosi inscripțiile date ale pieselor</p>	<p><b>CZ SK</b></p> <p>1. Montáž provádět na čistém a měkkém podkladu (lepenka, látka)</p> <p>2. Dodržujte příložené instrukce, abyste předešli poškození součástí</p> <p>3. Při reklamaci používejte příložené označení element</p>
<p><b>EL</b></p> <p>1. Η συναρμολόγηση του προϊόντος πρέπει να γίνει σε καθαρή και μαλακή επιφάνεια (χαρτόνι, ύφασμα).</p> <p>2. Για να μην φθαρούν τα στοιχεία, συμμορφωθείτε με τις οδηγίες που παρέχονται.</p> <p>3. Κατά τη δήλωση ελαττωματικού προϊόντος, αναφέρετε τους κώδικες των στοιχείων όπως αναφέρονται στο εγχειρίδιο.</p>	<p><b>RUS BLR</b></p> <p>1. Монтаж изделия выполнять на чистой и мягкой поверхности (картон, ткань)</p> <p>2. Для предотвращения порчи изделий необходимо придерживаться правил монтажа</p> <p>3. В случае предъявления претензии использовать данные обозначения элементов.</p>
<p><b>BG</b></p> <p>1. Монтажът трябва да бъде извършен върху чиста и мека основа /karton, тъкан/</p> <p>2. За да избегнете оцетяване на елементи, спазвайте дадените инструкции</p> <p>3. При наличие на рекламация, използвайте дадените кодове на елементи</p>	<p><b>HU</b></p> <p>1. A szerelés tisztaság és puha felületen (karton, anyag) kell végrehajtani.</p> <p>2. Károsodásnak elkerülése érdekében, tartsa be a megadott utasításokat.</p> <p>3. Reklamáció esetén hivatkozzon a bútor alkatrészein megadott jelekre.</p>
<p><b>SL</b></p> <p>1. Montažo opravimo na čisti in mehki podlogi (karton, tkanina)</p> <p>2. Da bi se ozognili poškodbam elementov, upoštevajte navodila.</p> <p>3. Pri reklamaciji uporabimo oznake elementov</p>	<p><b>BIH HR</b></p> <p>1. Montažu obavljati na čistoj i mekoj podlozi (karton, tkanina)</p> <p>2. Da bi izbegli oštećenja elemenata pridržavati se datih instrukcija</p> <p>3. Prilikom prijave reklamacije koristiti date oznake elemenata</p>
<p><b>MK</b></p> <p>1. Монтажа да се врши на чиста и мека подлога (karton, ткаенина)</p> <p>2. За да се избегне оштетување на елементите придржувајте се на дадените инструкции</p> <p>3. За пријава на рекламиции користете ги дадените ознаки на елементите</p>	<p><b>AL</b></p> <p>1. Montimi të bëhet në sipërfaqe të pastër dhe të butë (karton, pëlhurë)</p> <p>2. Që t'u shmangeni dëmtimit të elementeve, përmbahuni instrukcioneve të dhëna</p> <p>3. Me rastin e reklamimit përdorni shenjat e dhëna të elementit</p>
<p><b>PL</b></p> <p>1. Montować należy na czystej i miękkiej powierzchni (karton, tkanina)</p> <p>2. Aby uniknąć uszkodzenia elementów należy postępować ściśle według instrukcji.</p> <p>3. Przy zgłoszeniu reklamacji należy posługiwać się załączonymi oznaczeniami elementów.</p>	<p><b>HR</b></p> <p>1. Pažljivo pročitajte upute za montažu</p> <p>2. Pripremite sve dijelove namještaja</p> <p>3. Prikupite i provjerite okove za montažu</p> <p>4. Pripremite potreban alat</p> <p>5. Pripremite prostor za montažu</p> <p>6. Počnite montirati</p> <p>7. Sačuvajte ove ove upute</p> <p>8. Proizvod je namjenjen isključivo za kućnu uporabu</p>

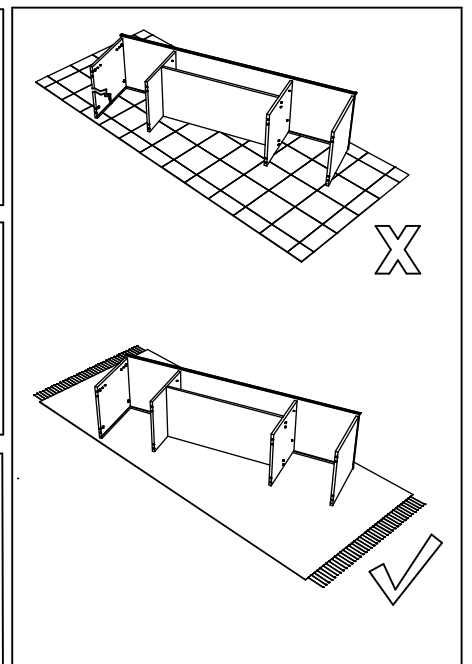
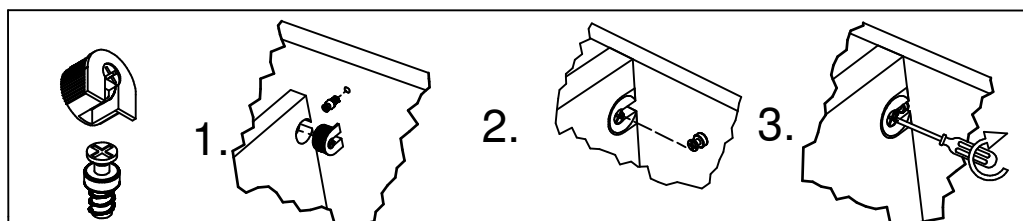
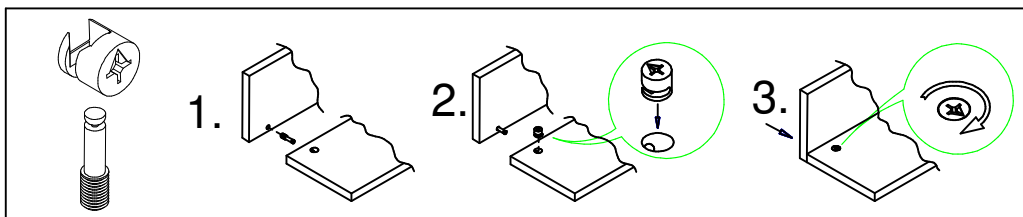

A	∅8x30	B	∅7x50	C		D		E		F		G		H		I	I1 I2 I3 I4	J	∅6.3x10
x60		x47		x18 (16+2)		x16		x13		x9		x2		x18		x4		x8	
K	∅8x60	L	1.6 x 25	M		N	3x25	O	3x16	P		Q	4x16	R		S	4x30	T	
x2		x82		x4		x16		x8		x6		x74		x2		x4		x9	
U		V		W		X	X1 X2	Y		Z	6x60	Aa		Ab	M4x25	Ac	3.5x16	Ad	
x6		x14		x4		x4		x4		x4		x13		x26		x24		x10	
Ae	∅7	Af	∅8	Ag	∅6,3x20	Ah	4x30	Ai		Aj	4x20	Ak		Al		Am		An	
x8 (2+6)		x6		x8		x7		x24		x4									

**1** A x 4  
∅8x30

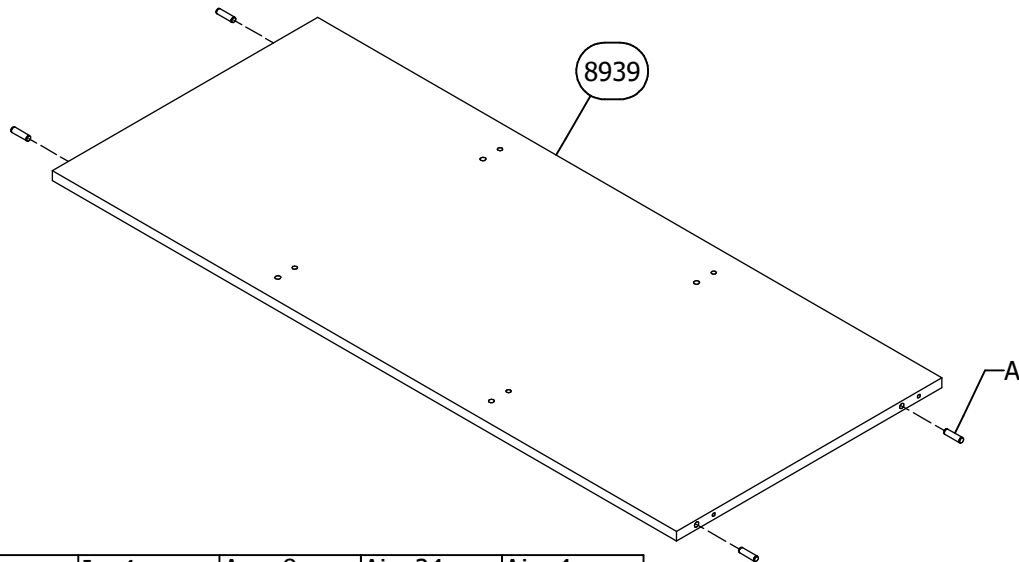

**2** A x 2  
∅8x30

I x 4  
I1

Ag x 8  
∅6,3x20

Ai x 24

Aj x 4  
4x20

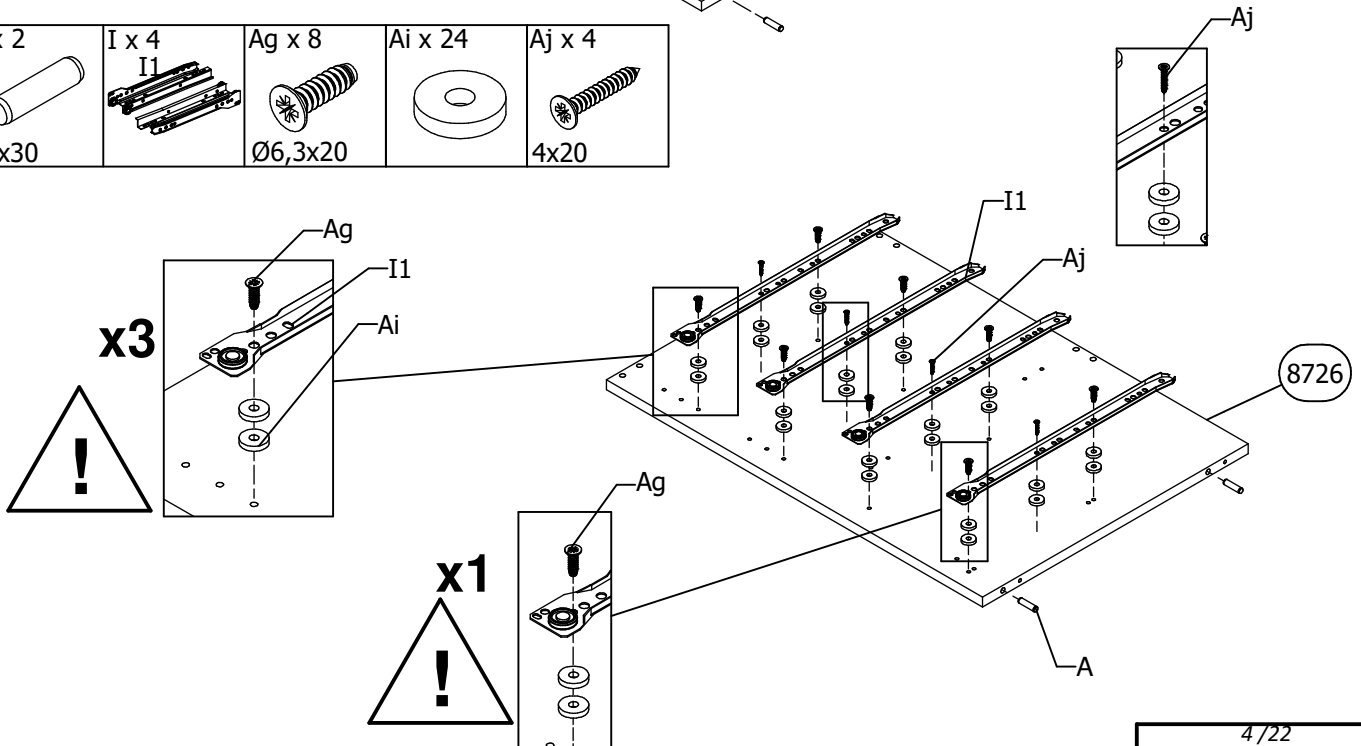

3

B x 2

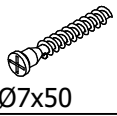

F x 1

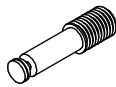

H x 2

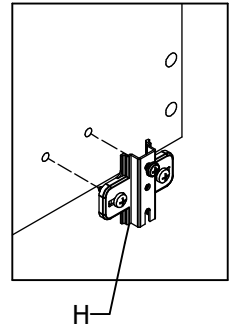
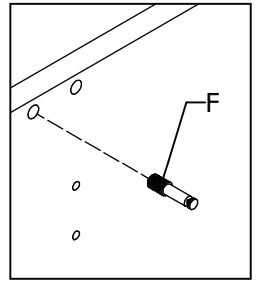
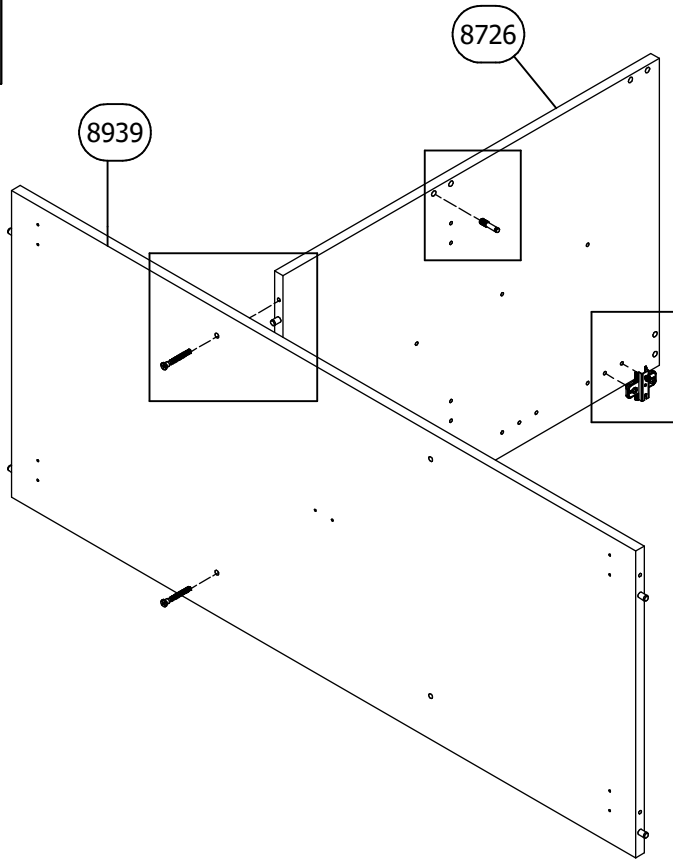
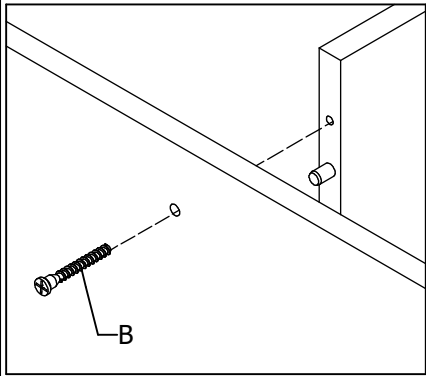
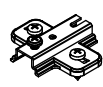

4

H x 2



4x

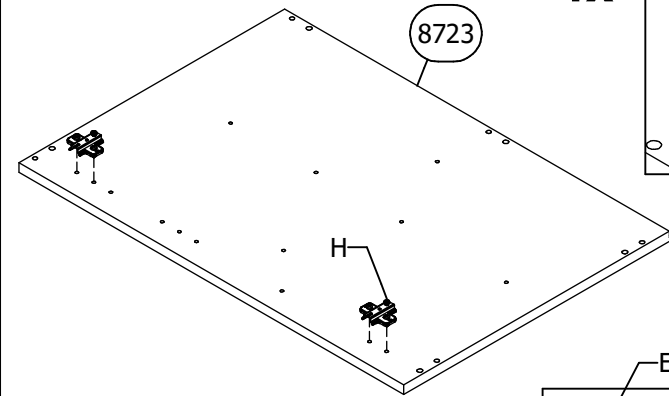
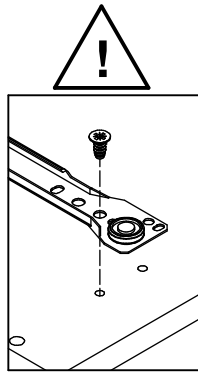

5

I x 4

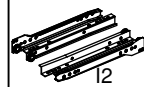

J x 8

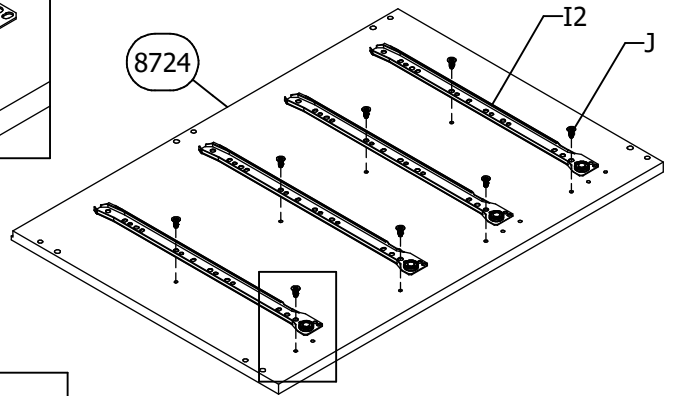

6

A x 2

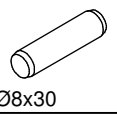

E x 2



K x 2

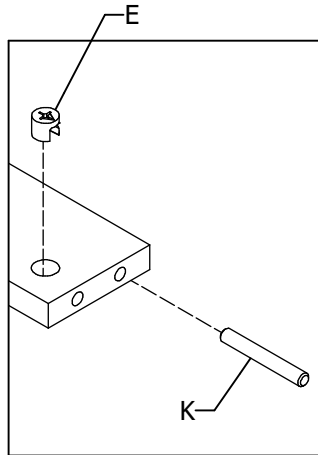
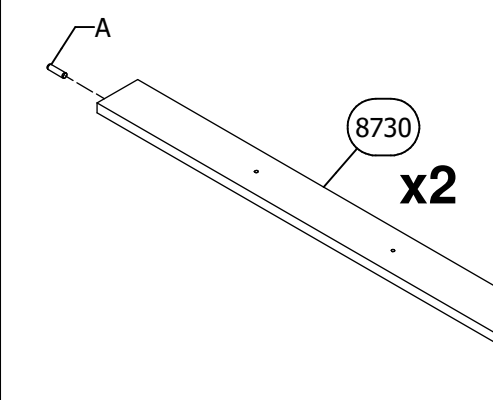
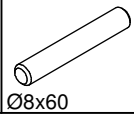

7

A x 2

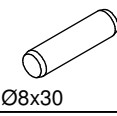

E x 1

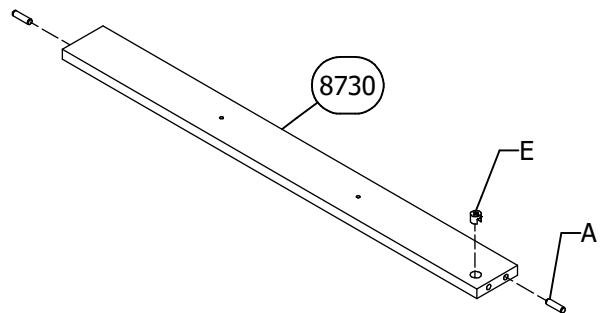

**8**

A x 2

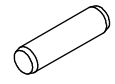

Ø8x30

E x 2

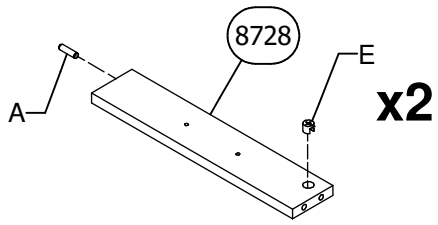
**9**

B x 9

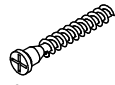

Ø7x50

C x 4

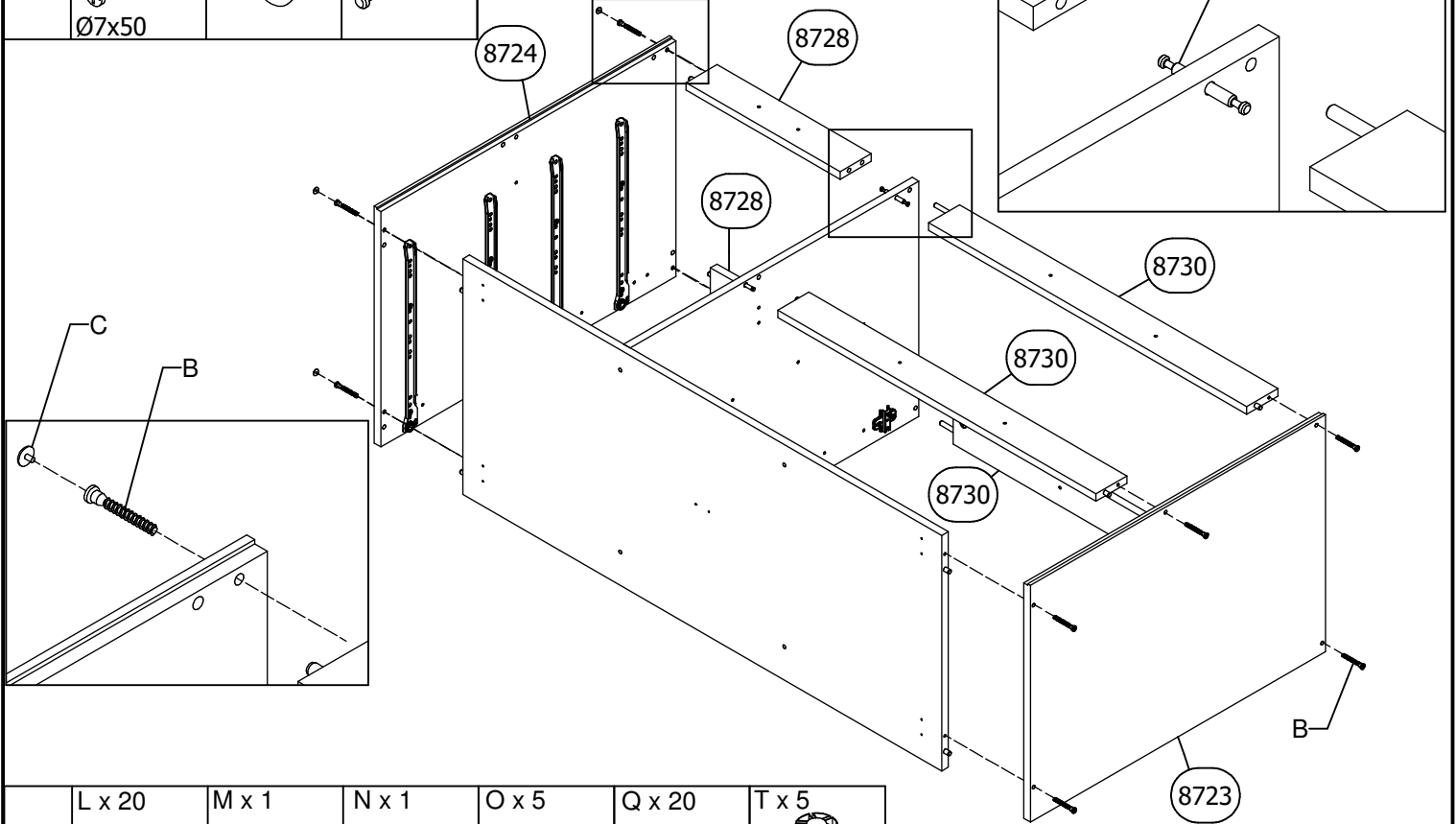
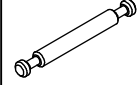

G x 2

**10**

L x 20



1.6 x 25

M x 1



N x 1



3x25

O x 5



3x16

Q x 20





4x16

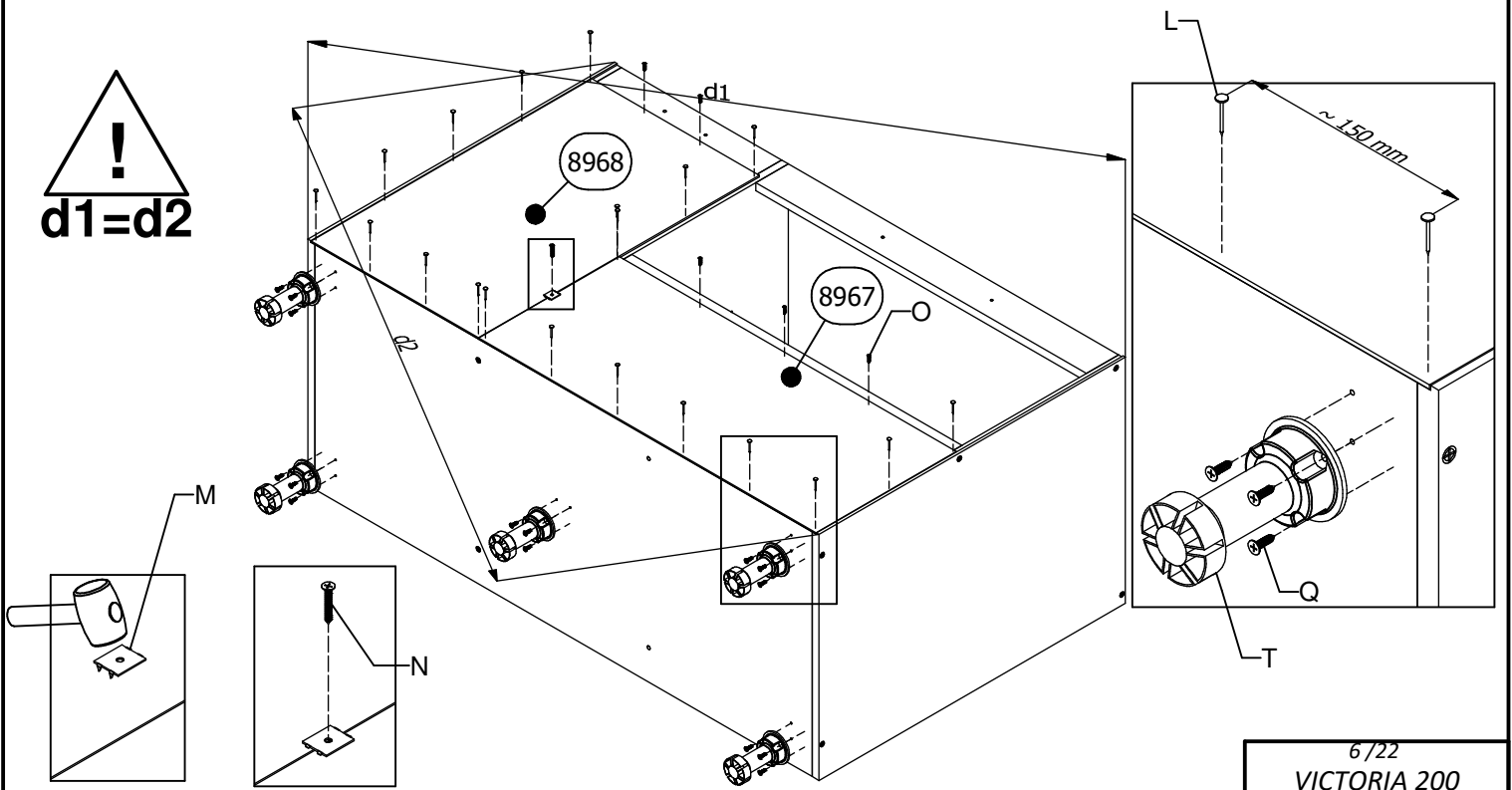
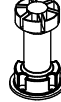

T x 5

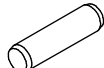

**11**

A x 2  Ø8x30	Q x 1  4x16	U x 1 
--	---	---

**12**

Q x 2  4x16	U x 2 
--	---

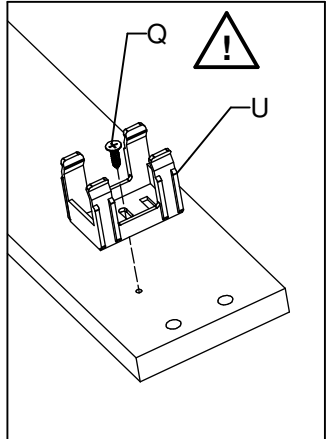
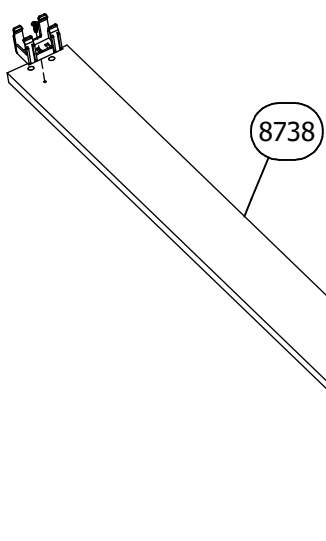
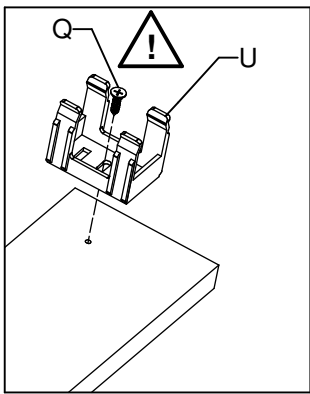
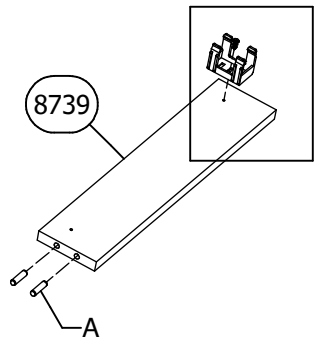



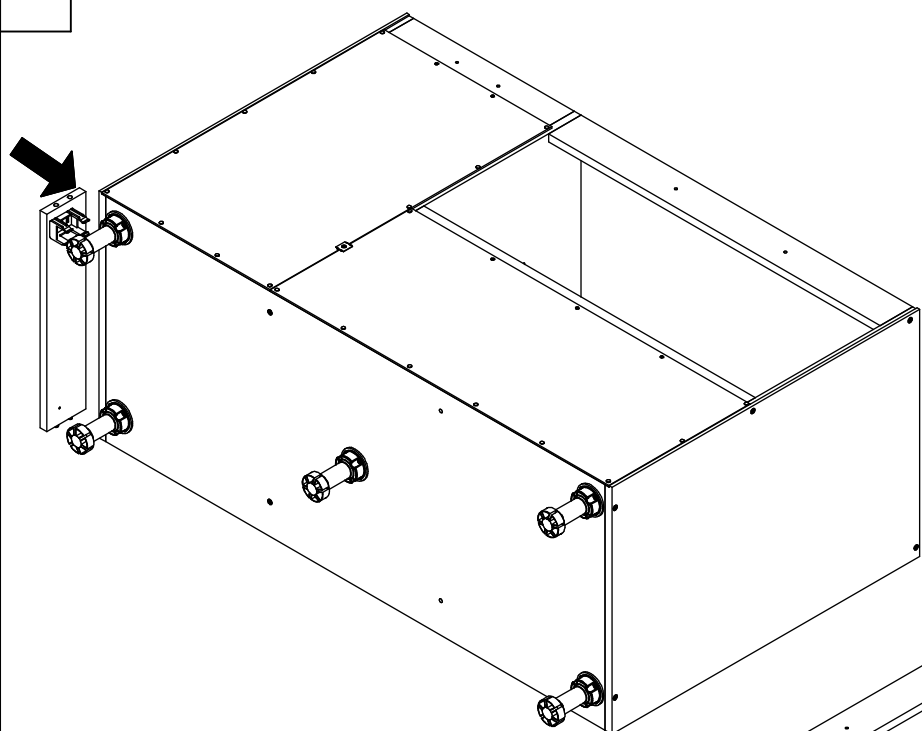

**13**

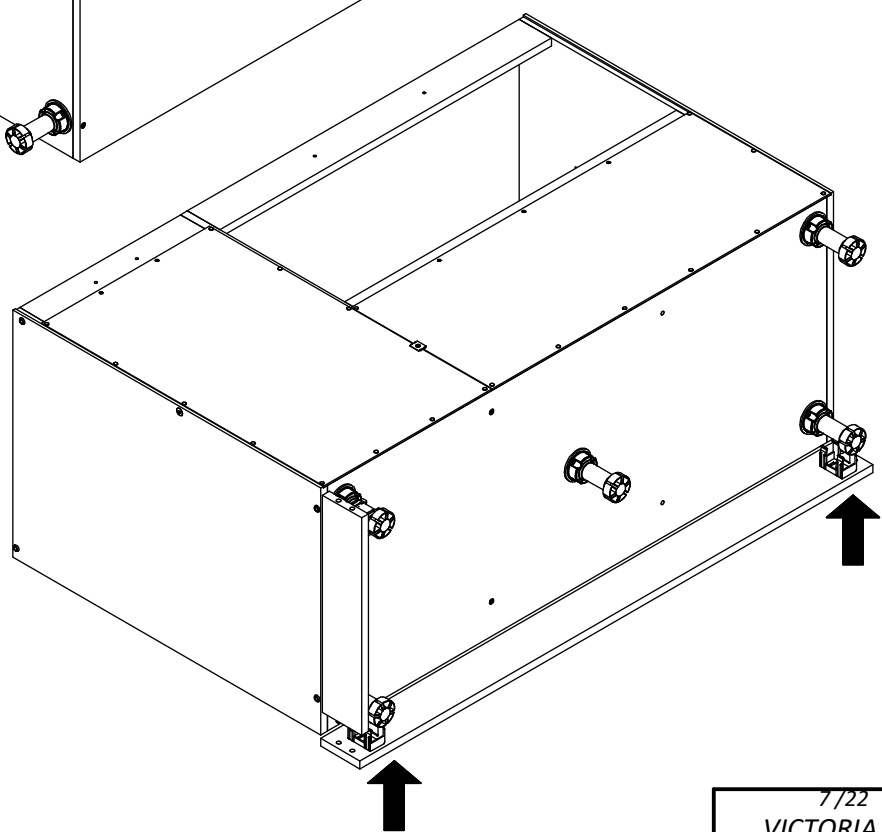

**14**



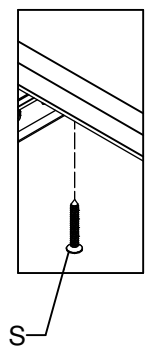
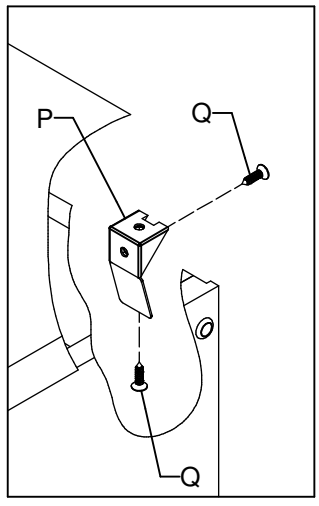
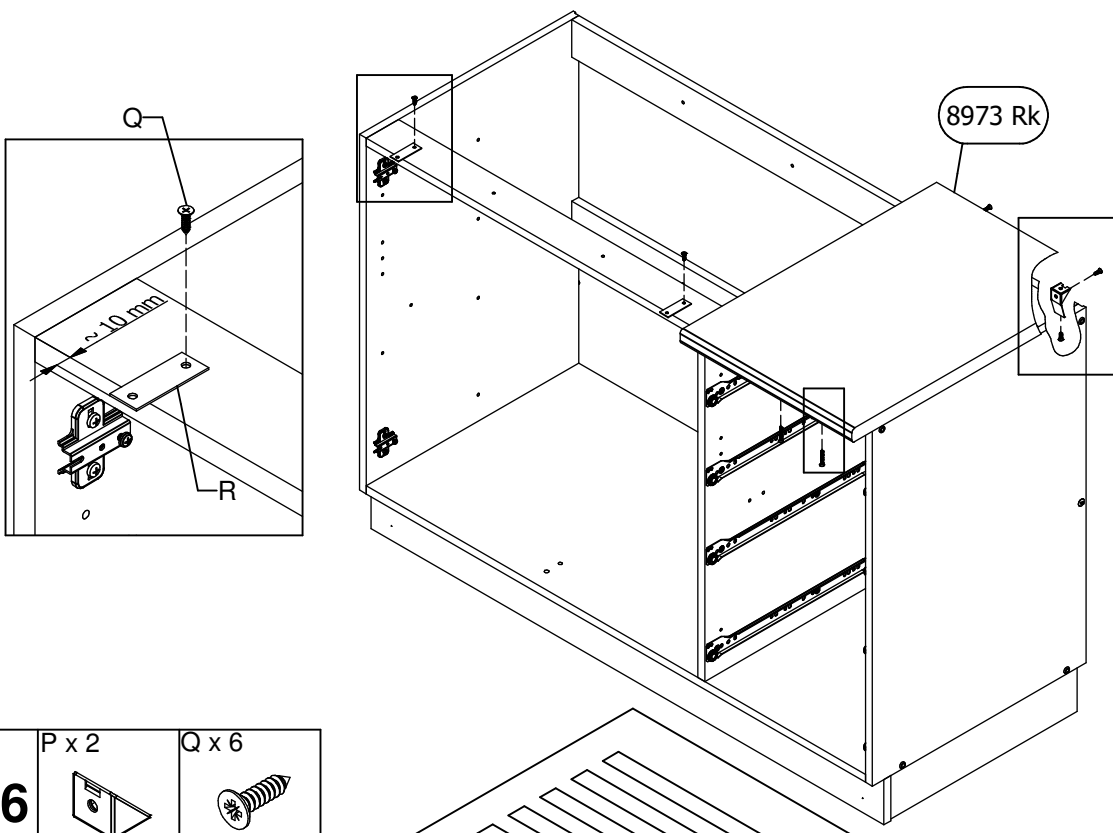

15

P x 2 	Q x 6  4x16	S x 2  4x30	R x 2 
---	---	---	---



16

P x 2 	Q x 6  4x16
--	--

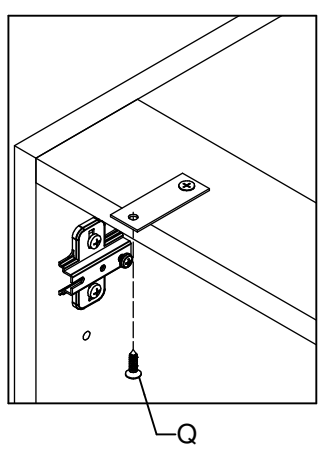
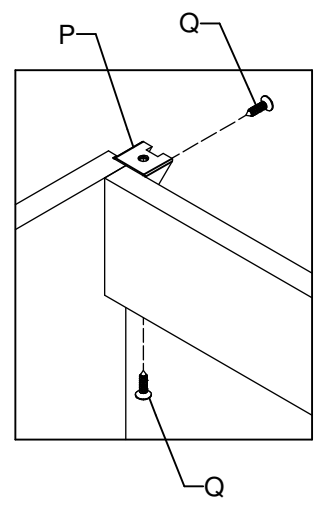
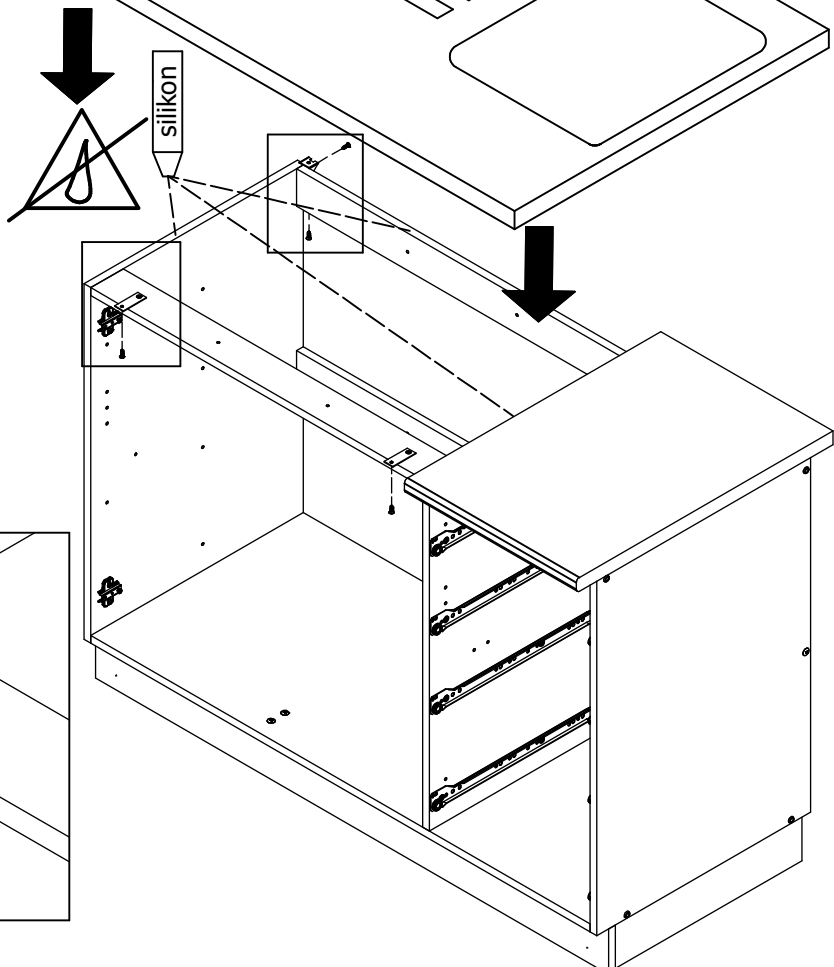



**17** D x 2 H x 2

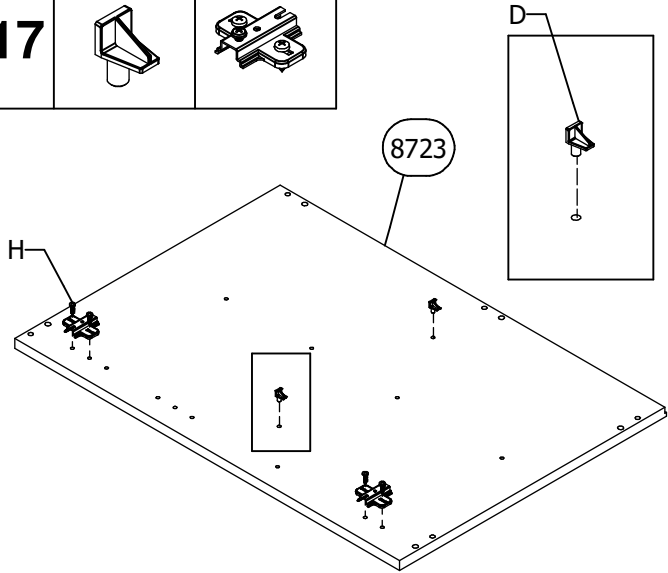

**18** D x 2 H x 2

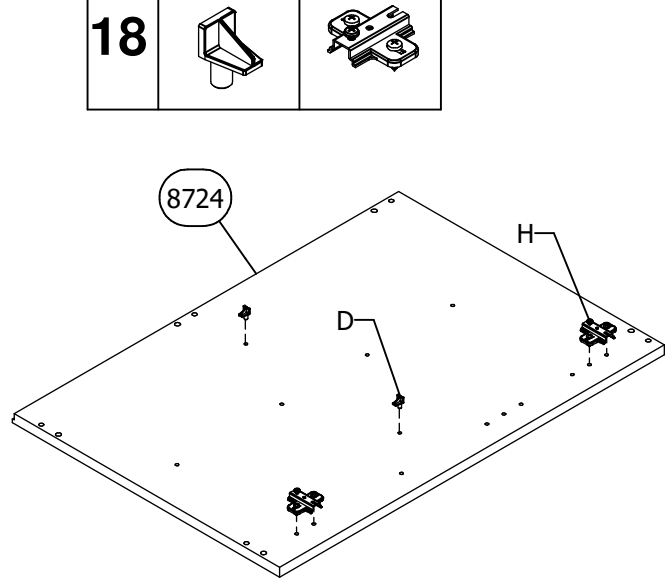

**19** A x 4  
Ø8x30

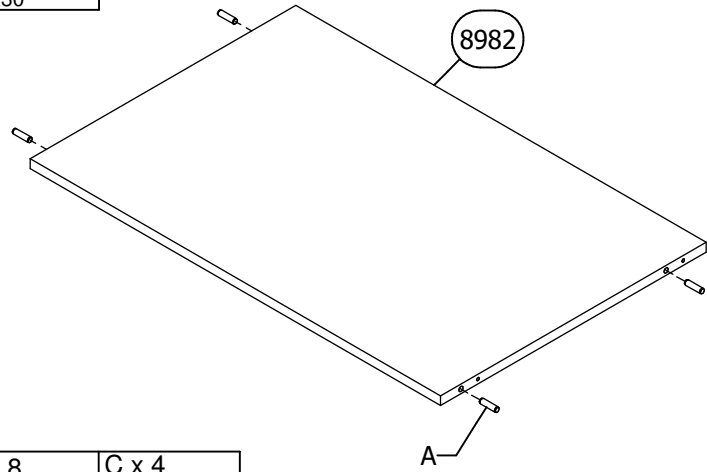

**20** A x 4  
Ø8x30

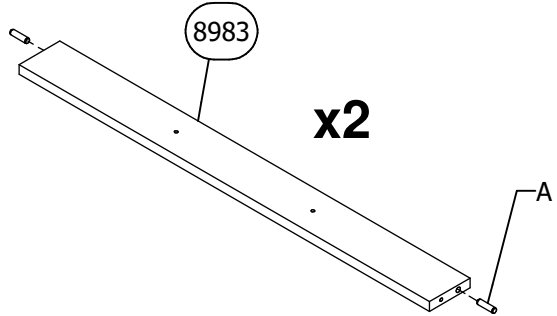

**21** B x 8 C x 4  
Ø7x50

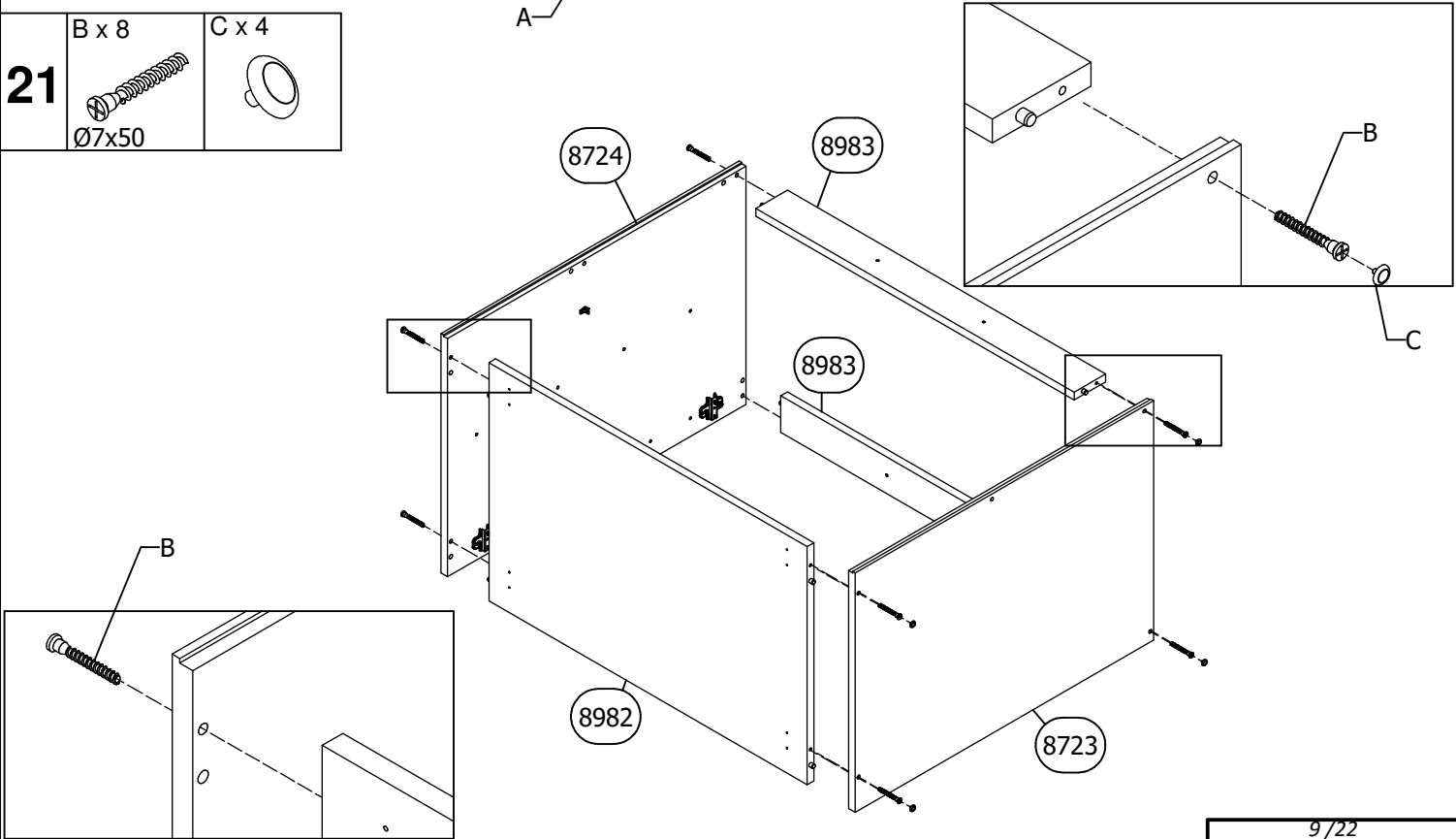

22

L x 16

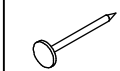

1.6 x 25

O x 3



3 x 16

Q x 16



4 x 16

T x 4



**d1=d2**

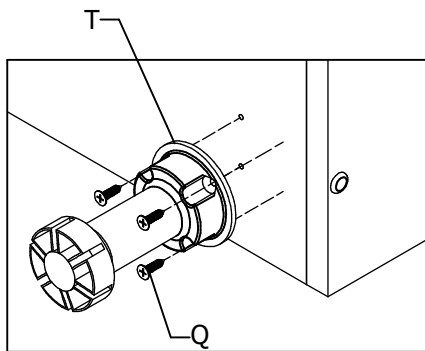
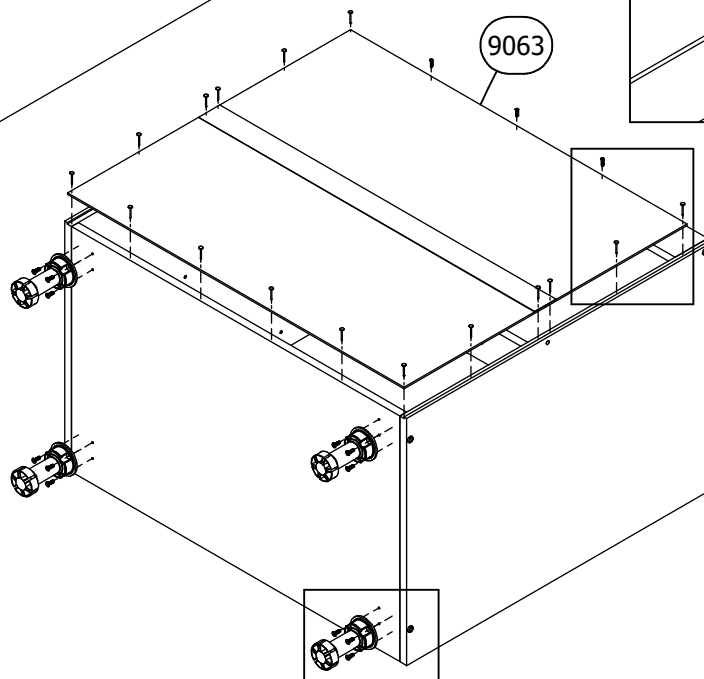
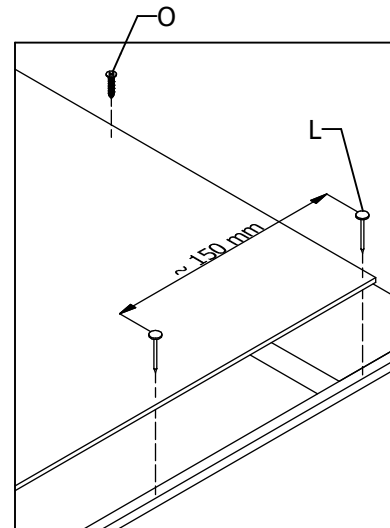
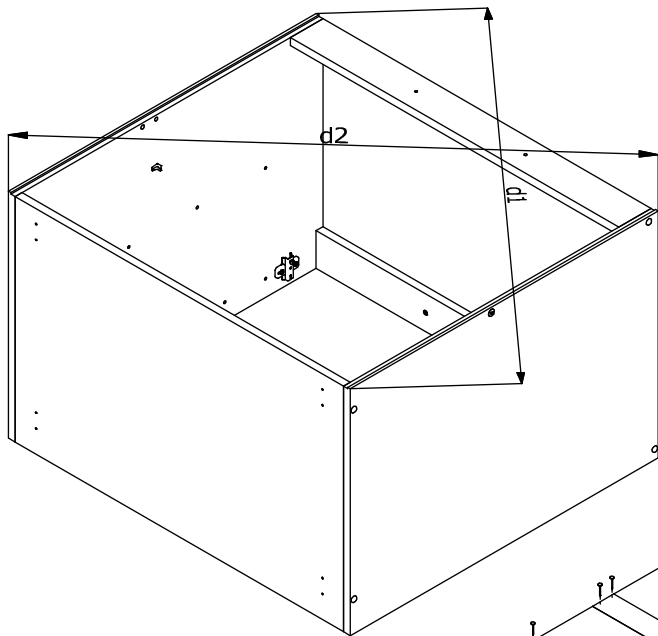

23

A x 2

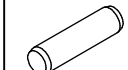

Ø8x30

Q x 1



4 x 16

U x 1



24

Q x 2



4 x 16

U x 2

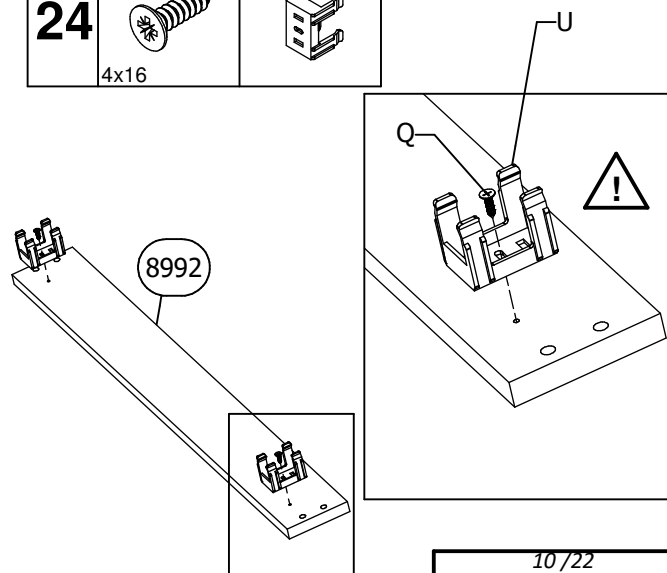
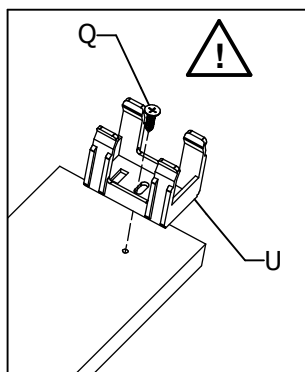
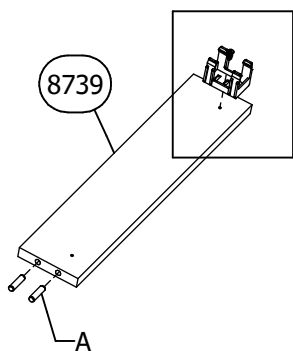

25

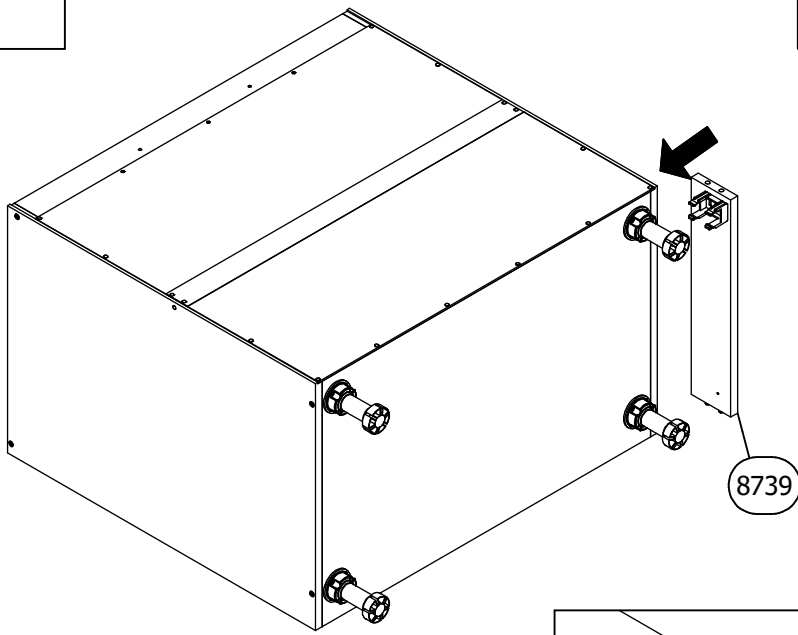

26

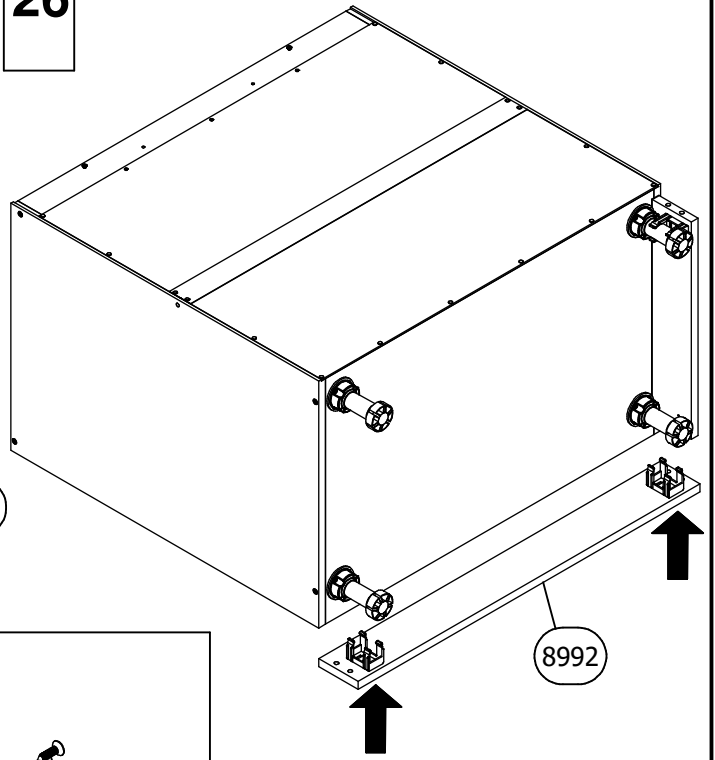

27

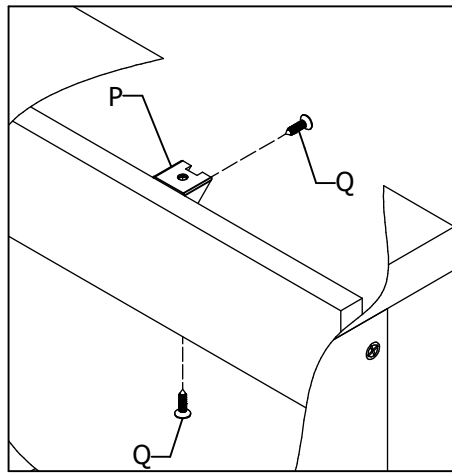
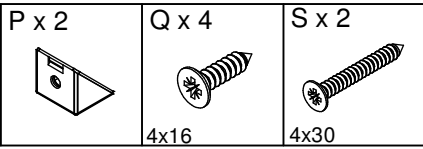

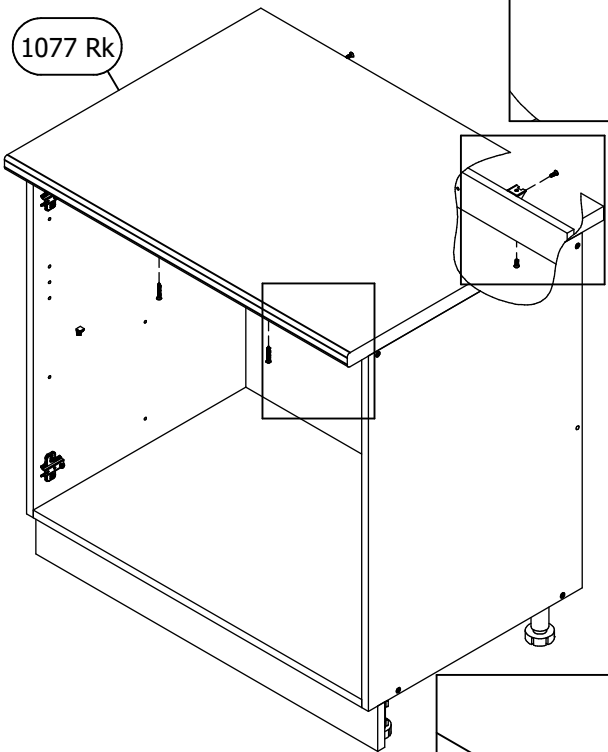

1077 Rk



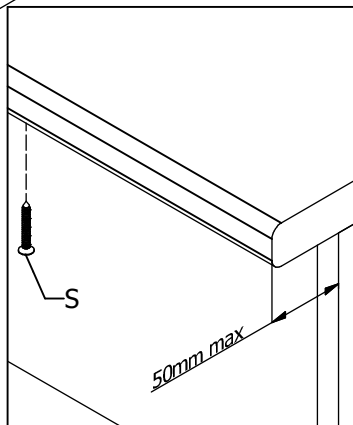
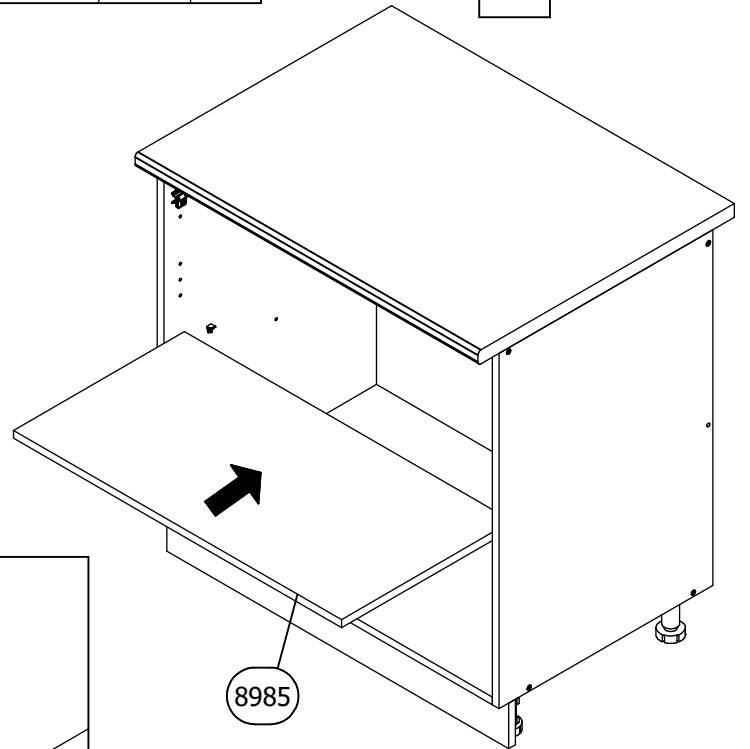

28



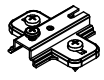

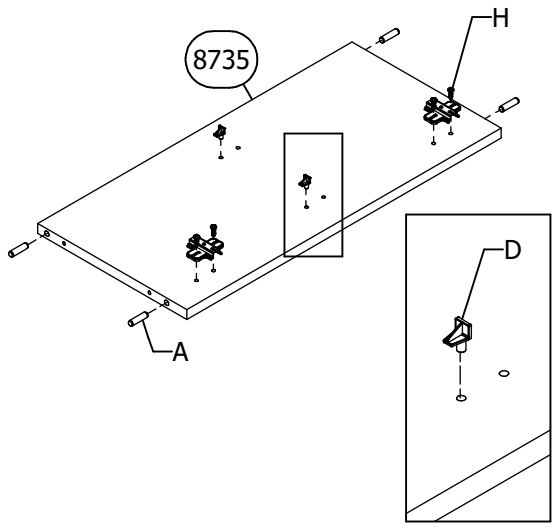
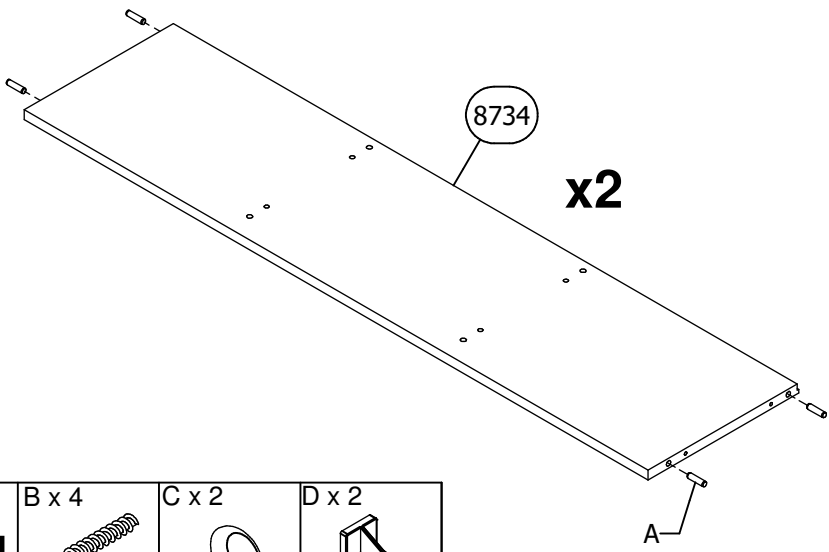
**29** A x 8  
  
 Ø8x30

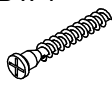
**30** A x 4    D x 2    H x 2  
        

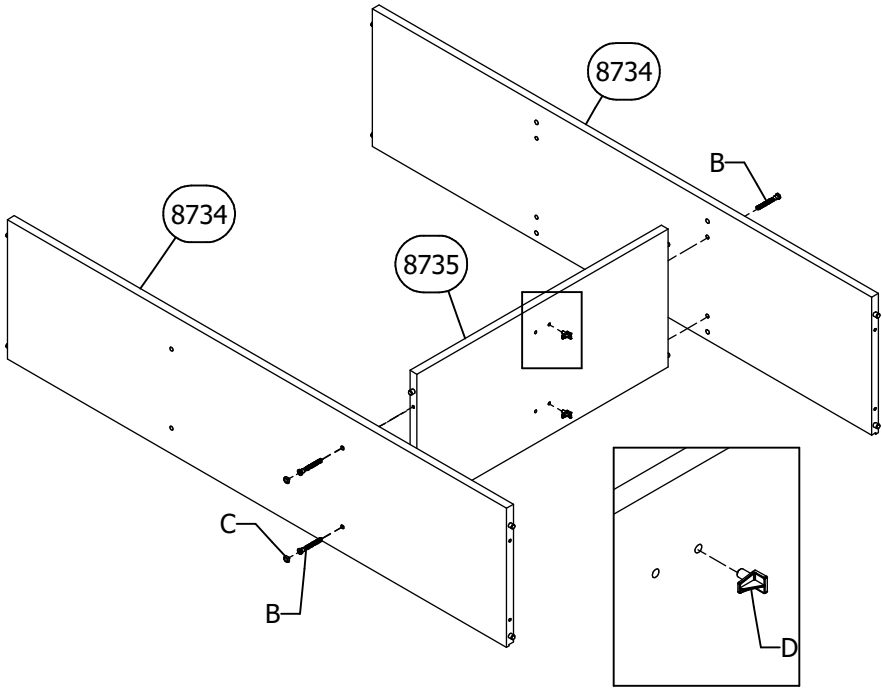

**31** B x 4    C x 2    D x 2  
          
 Ø7x50



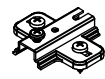

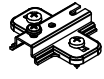
**32** D x 2    H x 2  
    

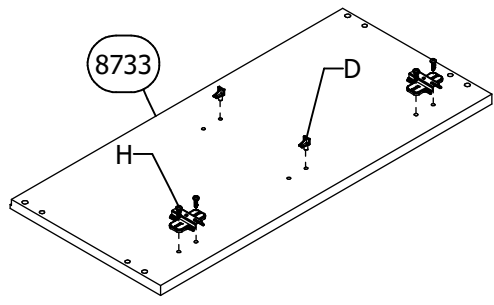
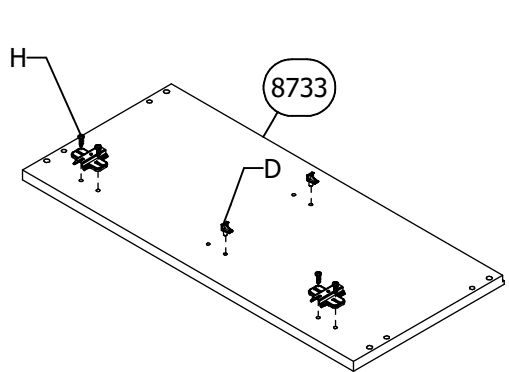
**33** D x 2    H x 2  
    



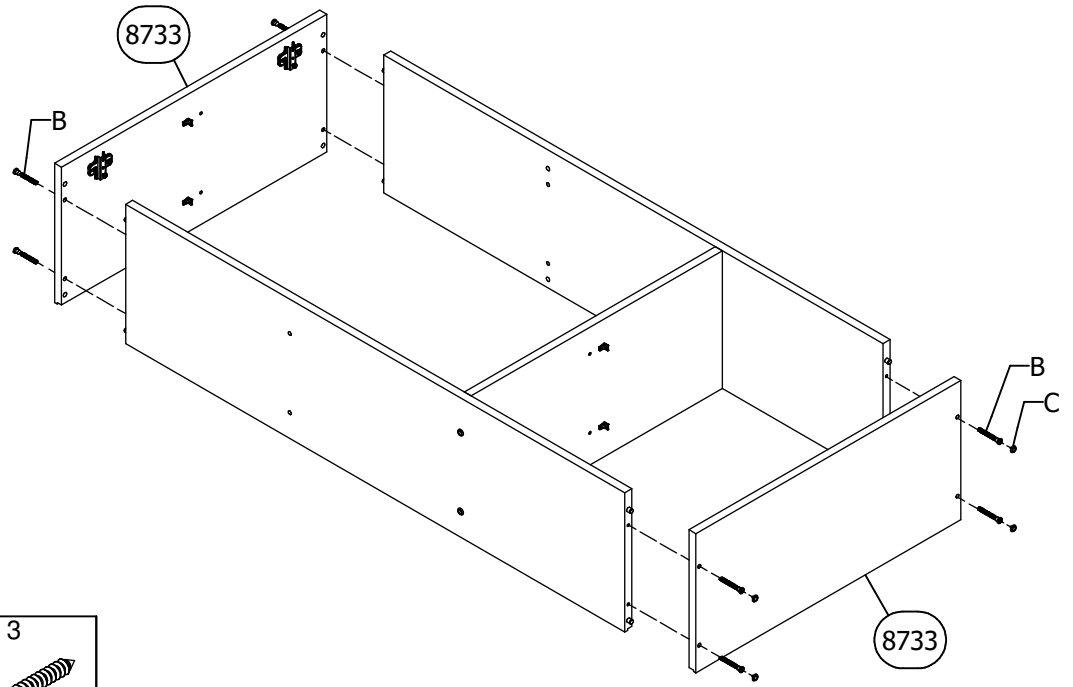

**34**

B x 8	C x 4
	
Ø7x50	



**35**

L x 26	M x 3	N x 3
		
1.6 x 25		3x25

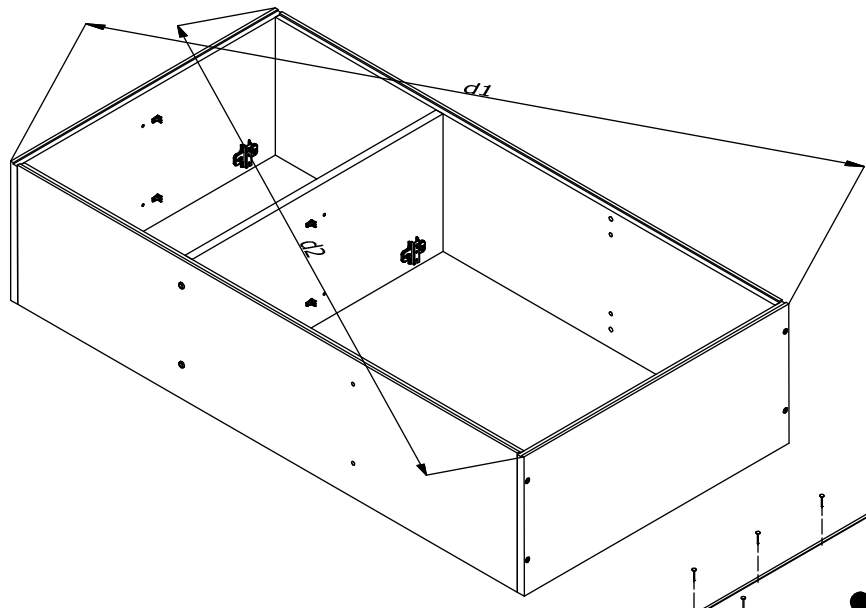

**!**  
**d1=d2**

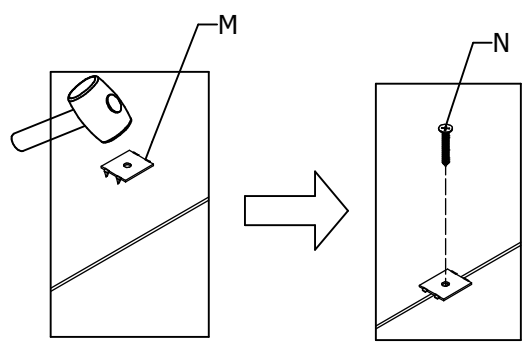
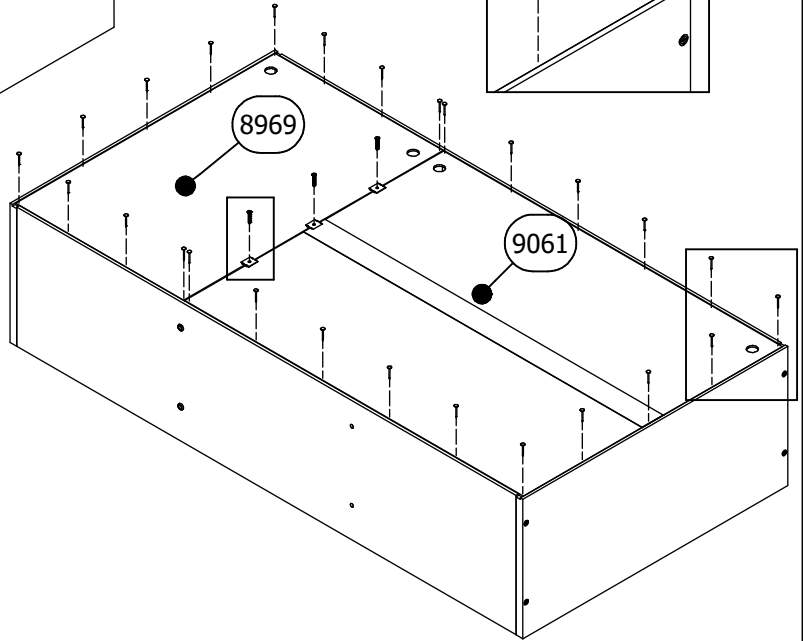
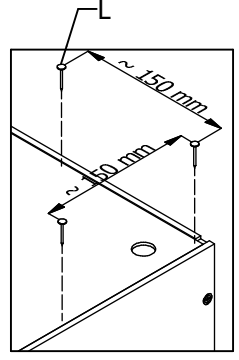

**36** D x 2 H x 2

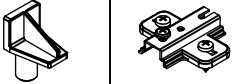

**37** D x 2 H x 2

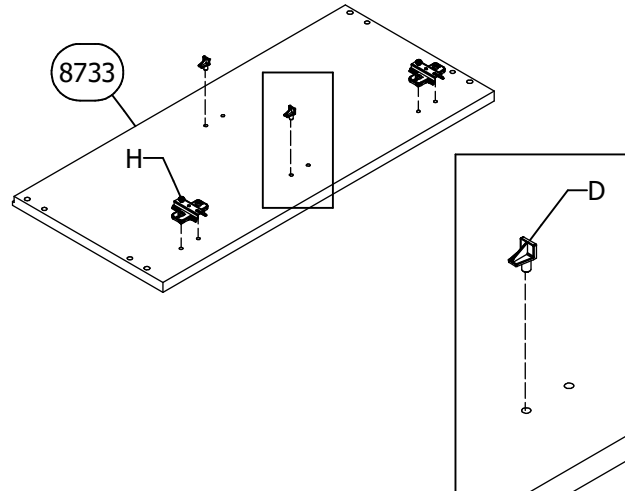
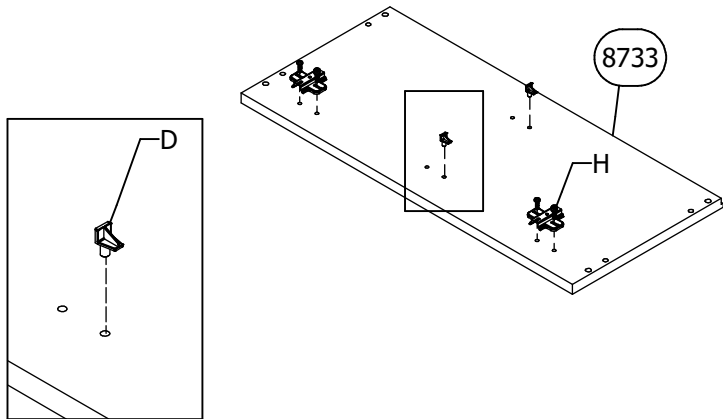
**38** A x 8  
Ø8x30

**39** B x 8 C x 4  
Ø7x50

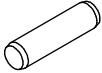
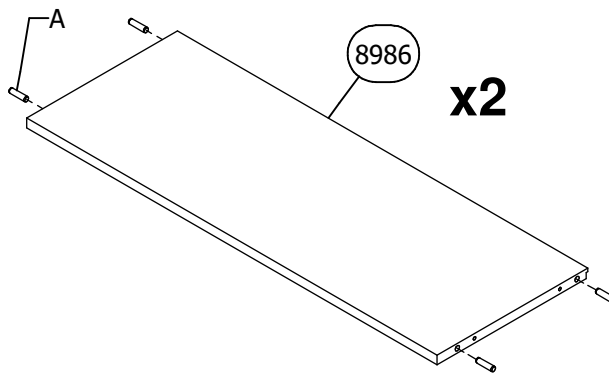
40

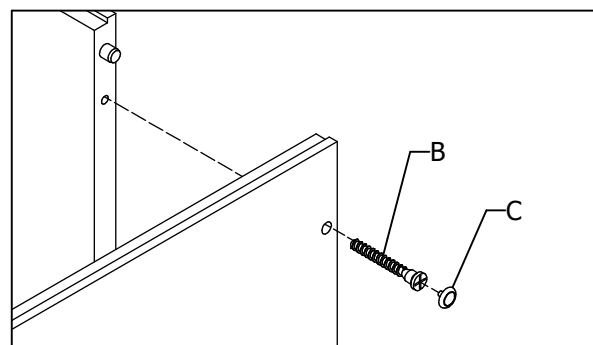
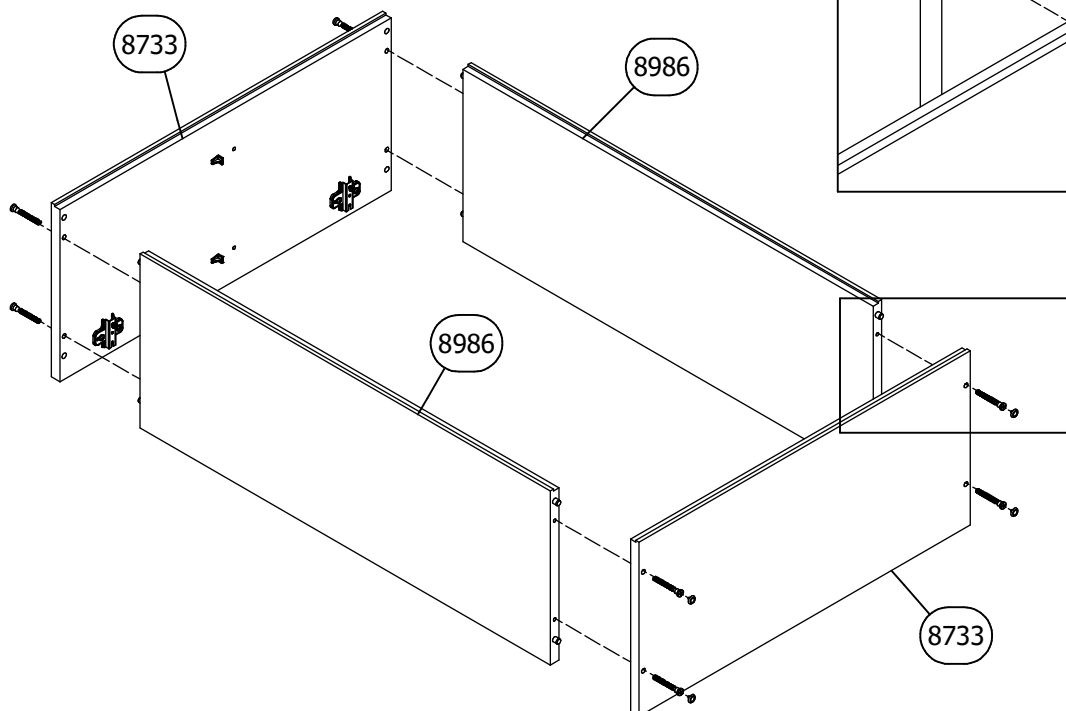

41

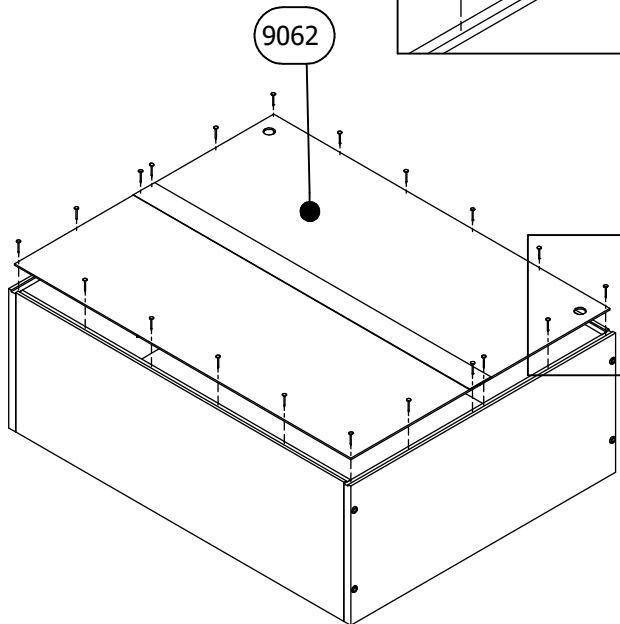
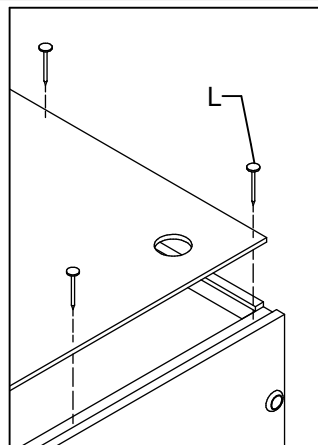
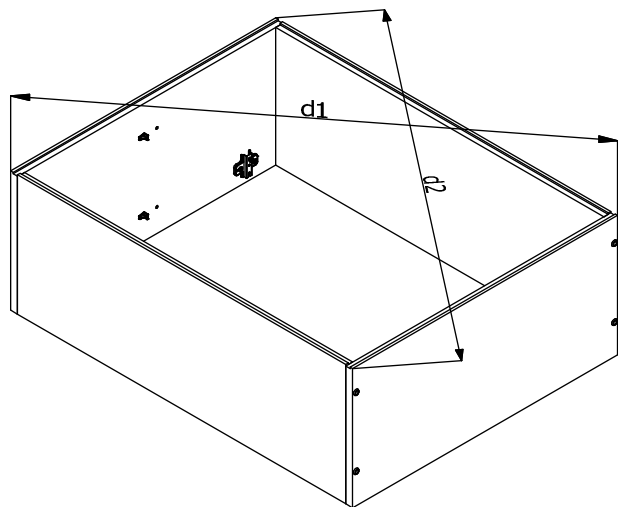
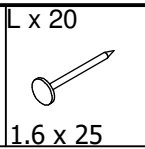

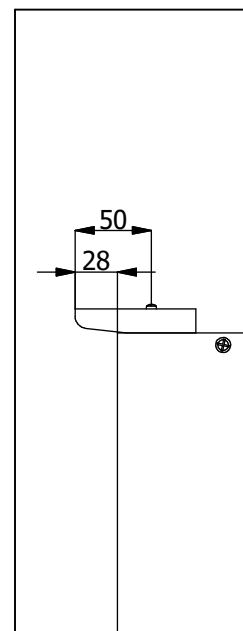
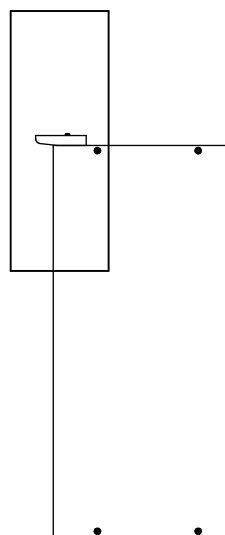
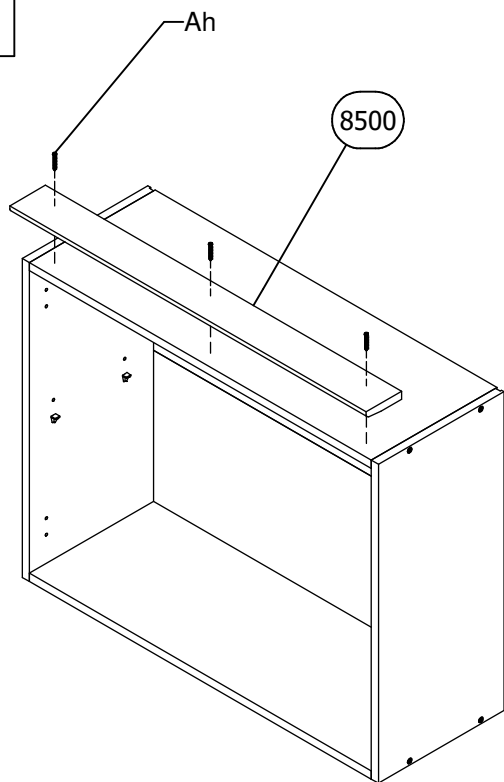
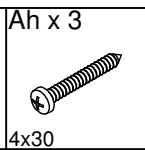
42

Ah x 4

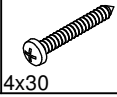

4x30

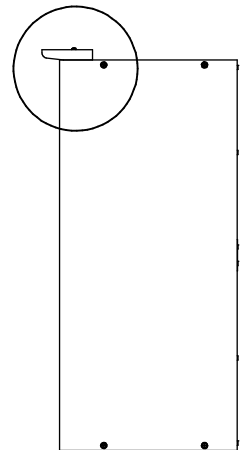
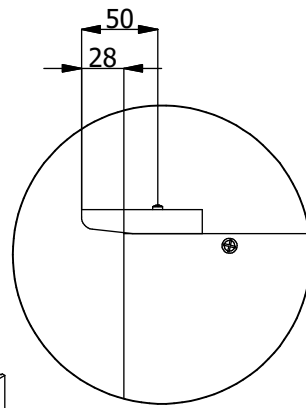
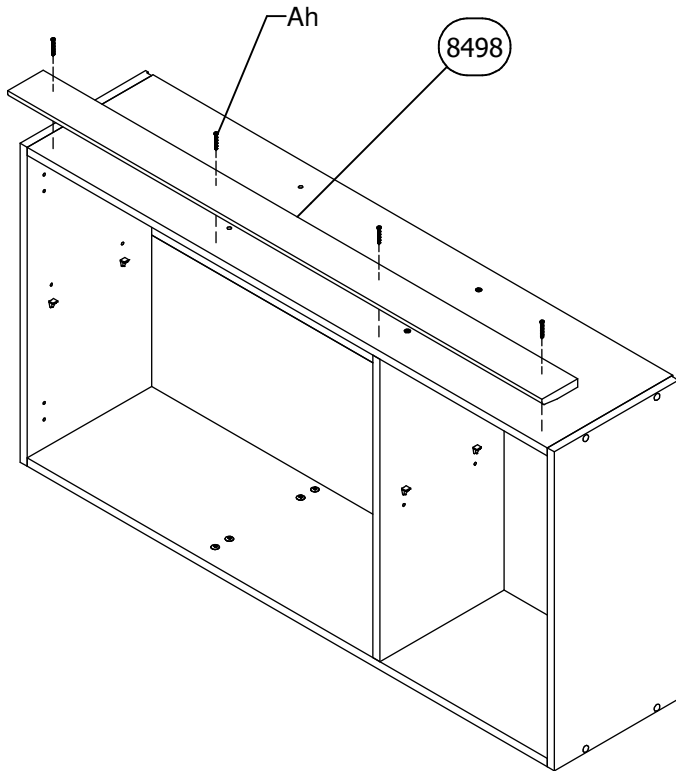

43

Q x 16



4x16

X x 4

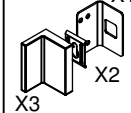

X3

Y x 4

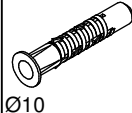

Ø10

Z x 4



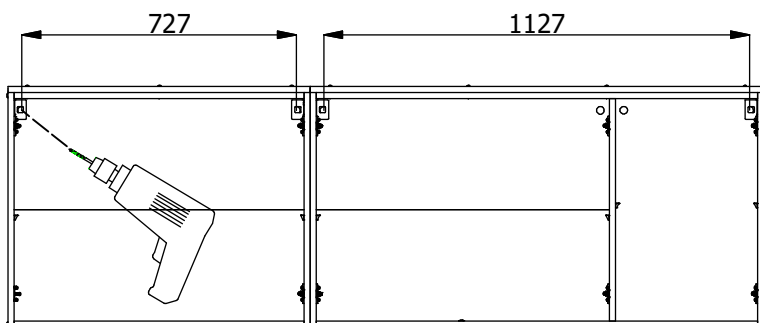
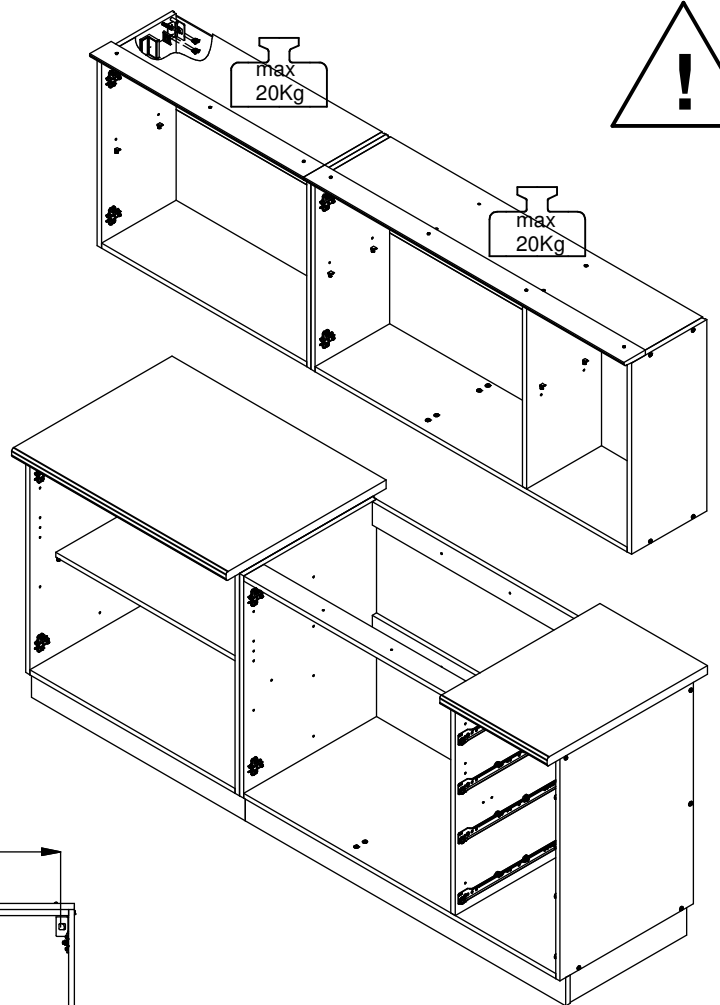
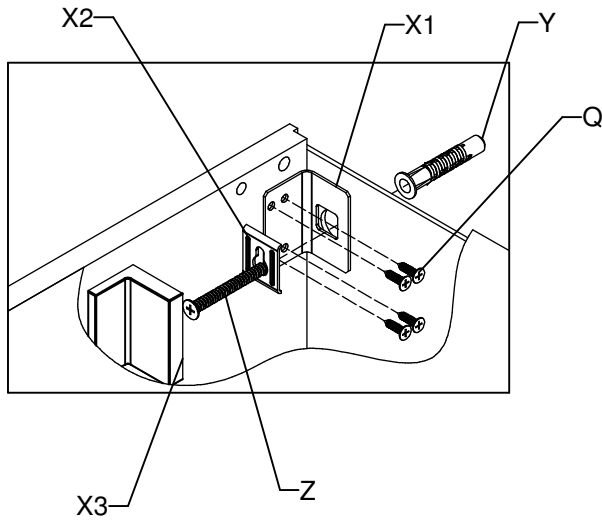

6x60







44

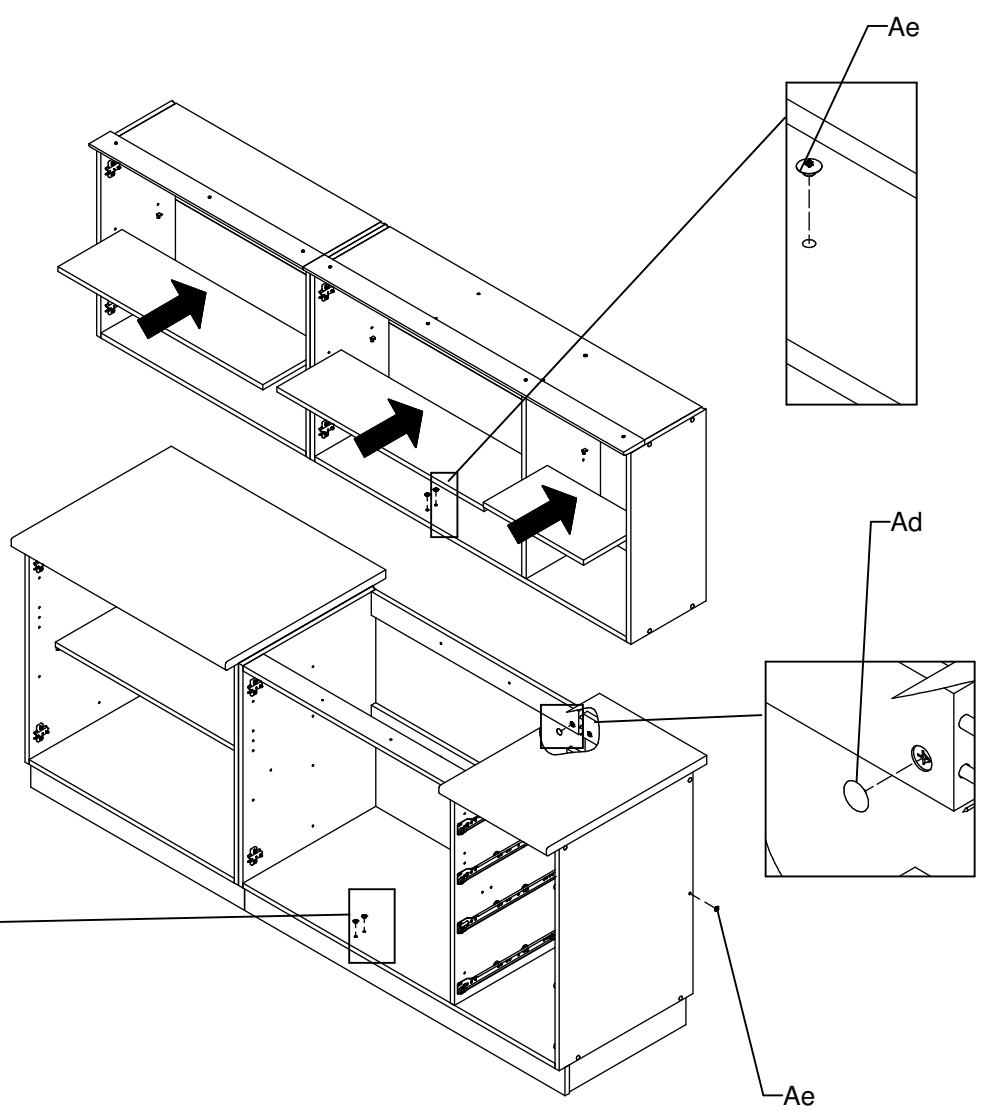

Ad x 2	Ae x 8 (6+2)	Af x 6
		
	Ø7	Ø8



45

A x 4	E x 4
	
Ø8x30	

46

A x 4	E x 4
	
Ø8x30	

x4

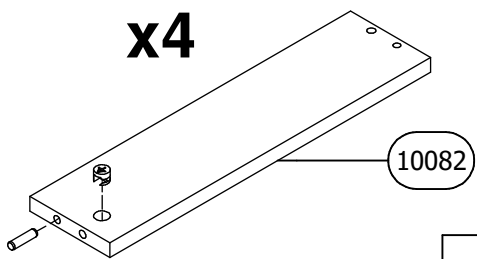

x4

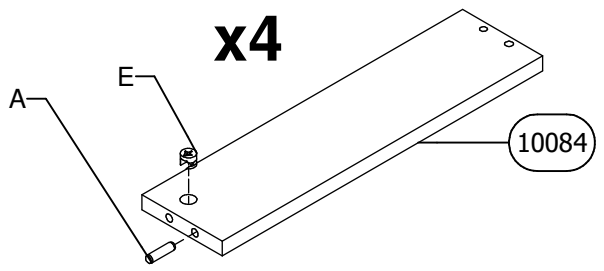

47

A x 8

Ø8x30

48

B x 8

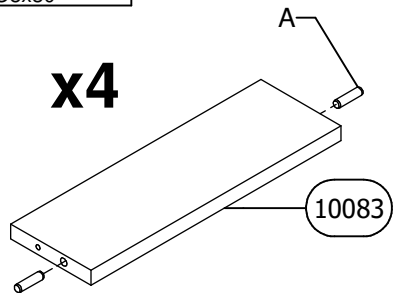
Ø7x50

x4

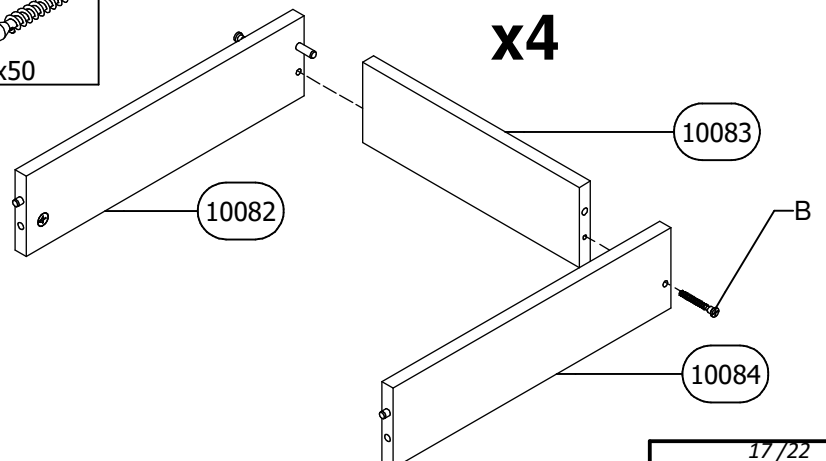

x4

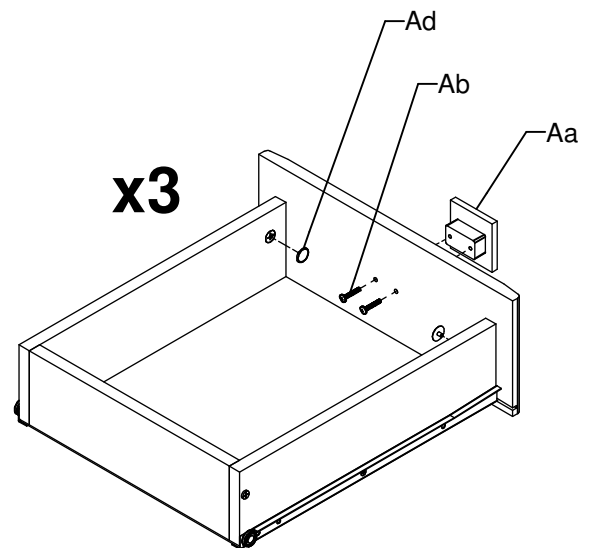
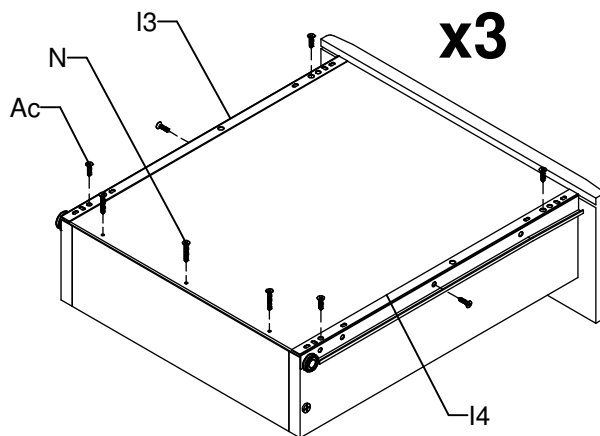
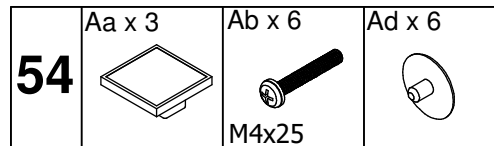
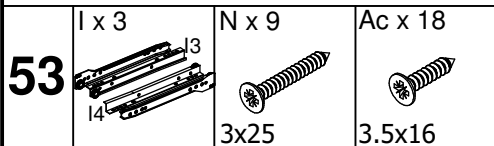
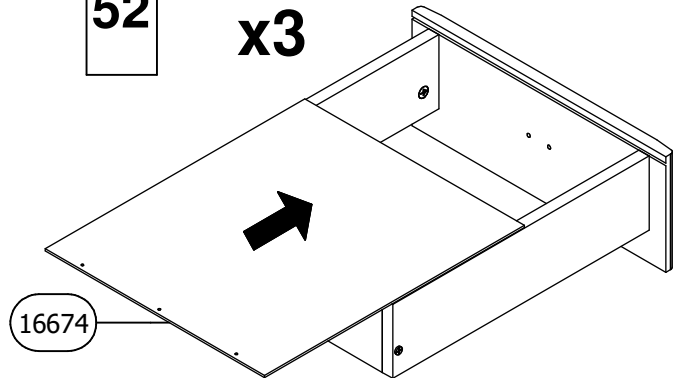
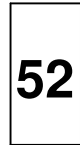
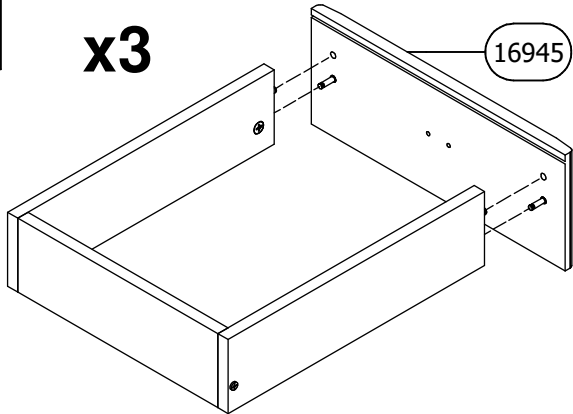
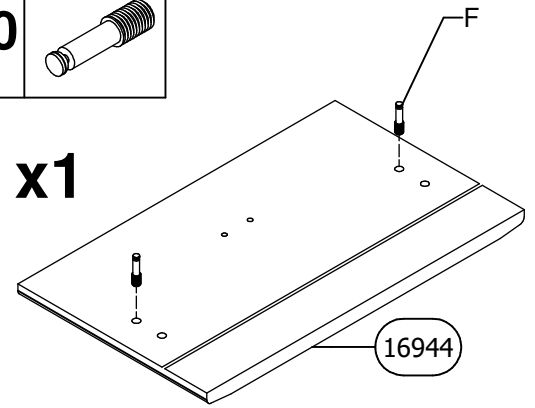
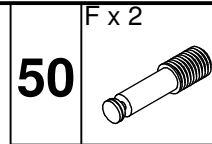
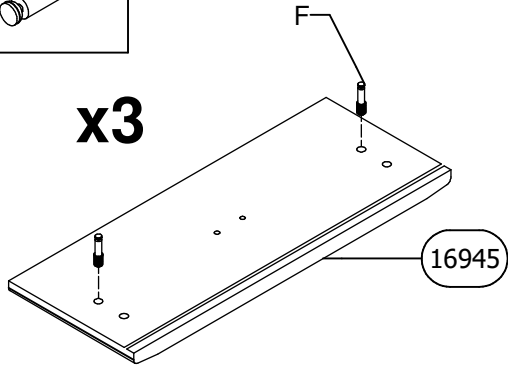
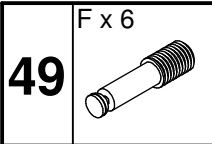



55

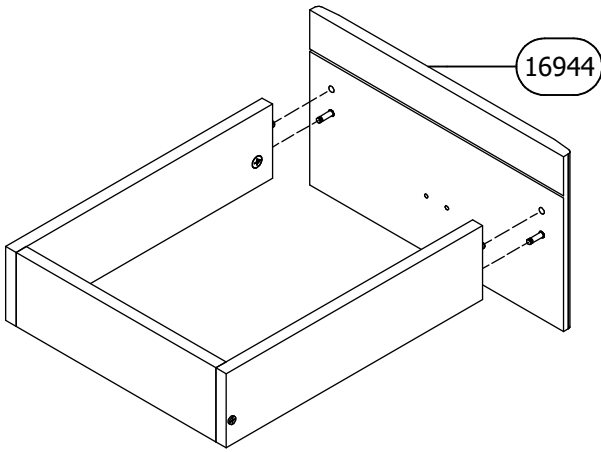

56

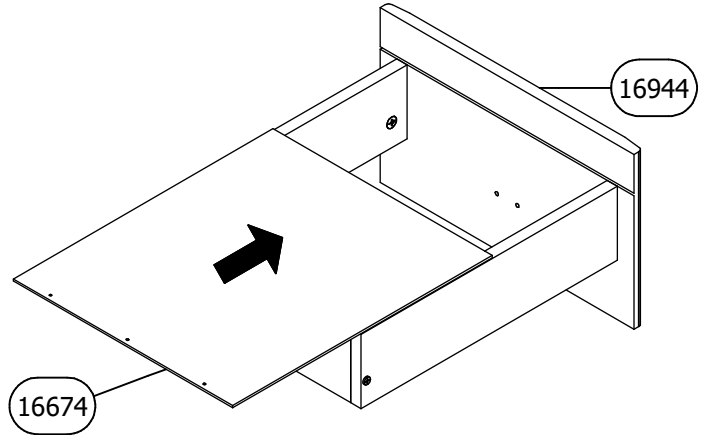

57

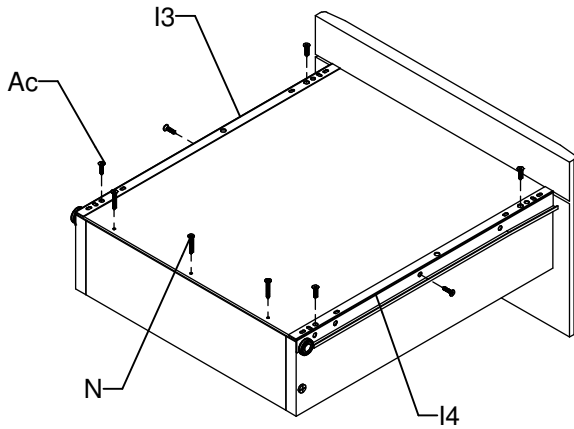
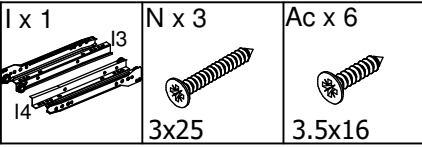

58

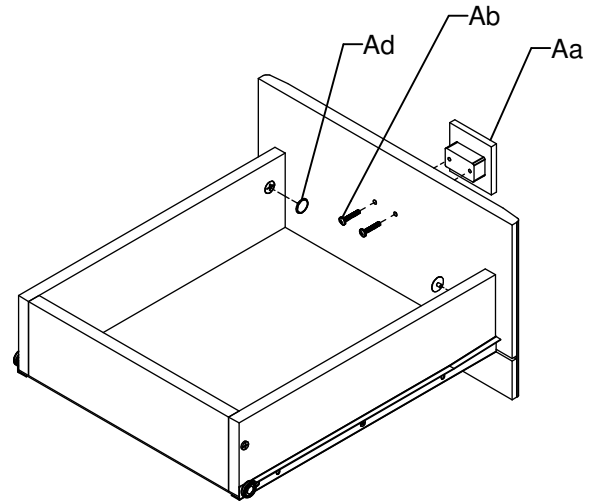
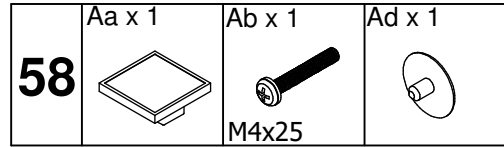

59

V x 2

Aa x 1

Ab x 2

M4x25

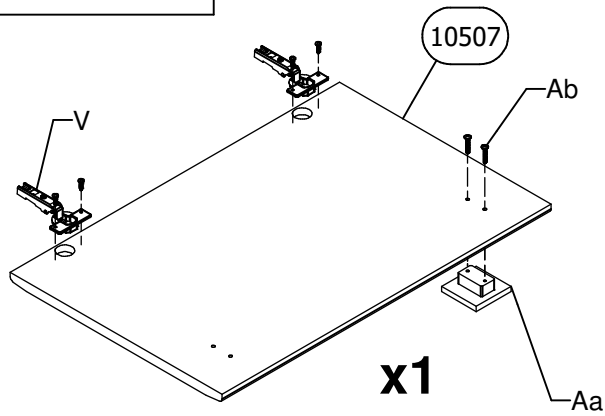
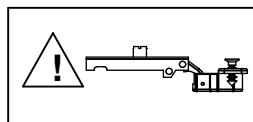
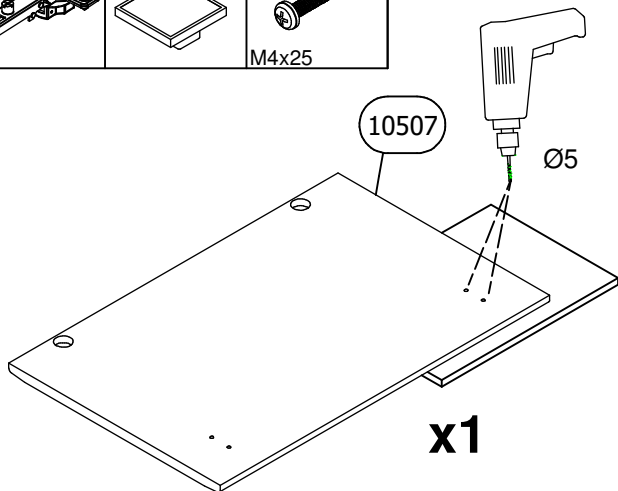
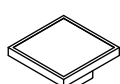
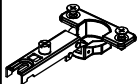

60

V x 4

Aa x 2

Ab x 4

M4x25

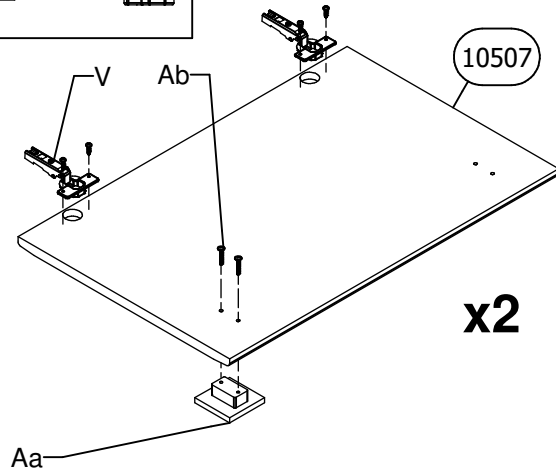
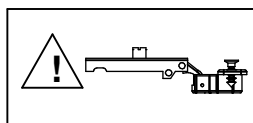
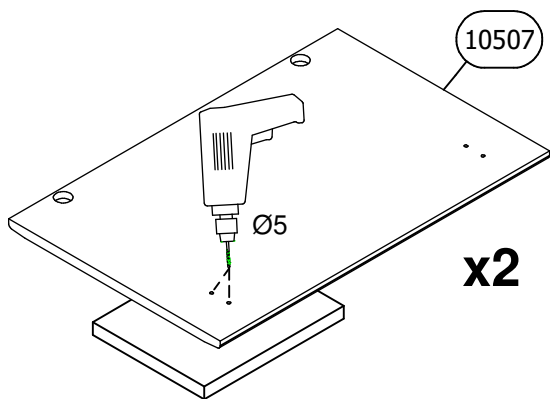
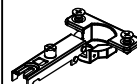

61

W x 2

V x 2

Aa x 2

Ab x 4

M4x25

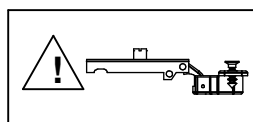
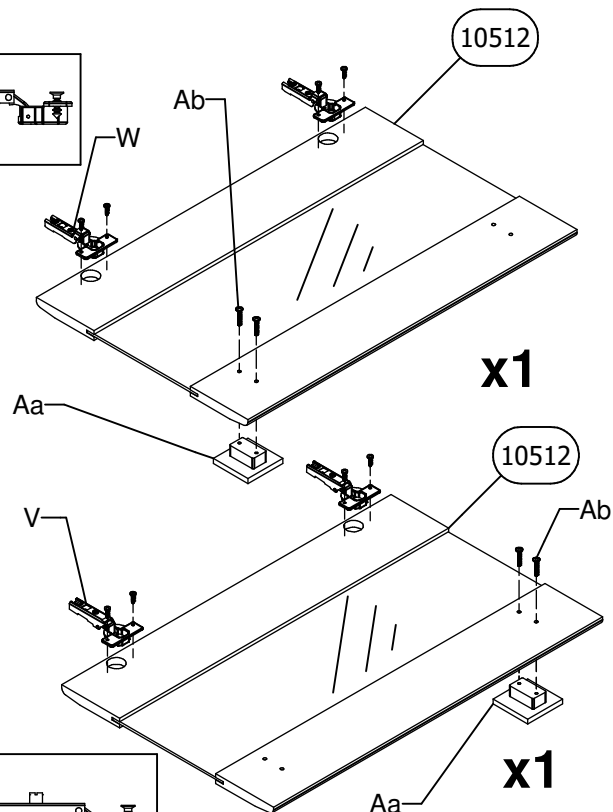
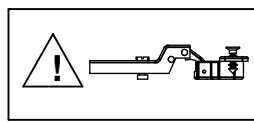
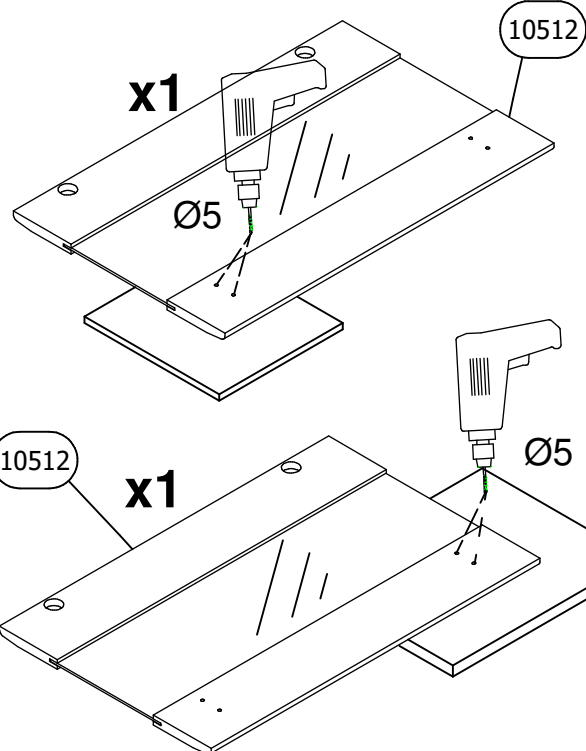
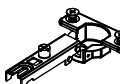

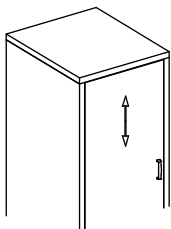
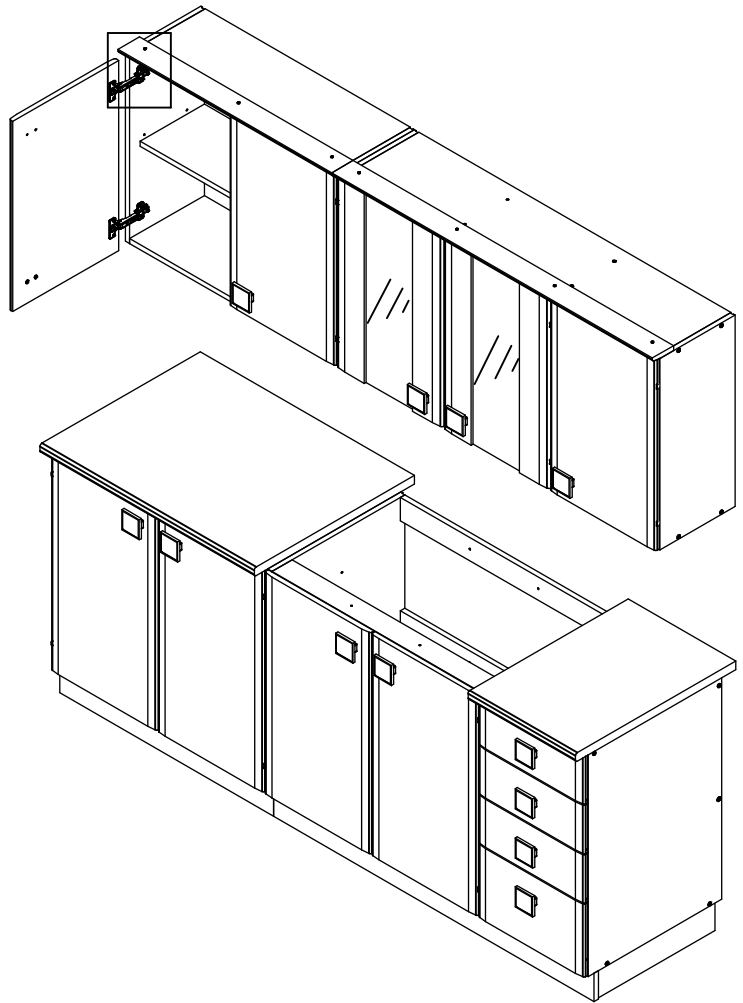
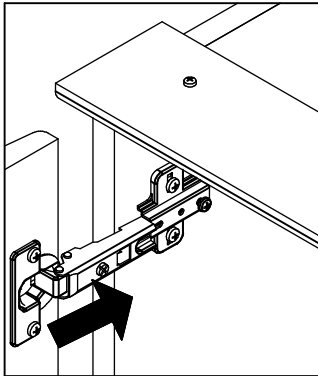

1.

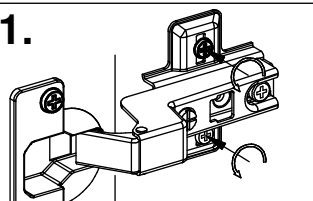

2.

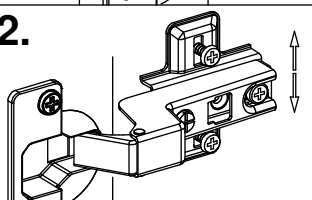

3.

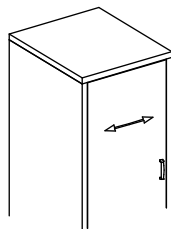
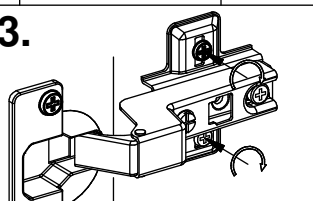

1.

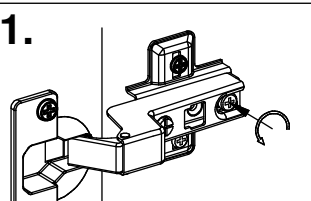

2.

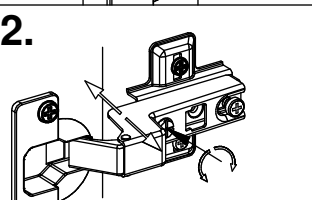

3.

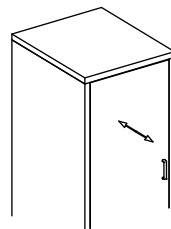
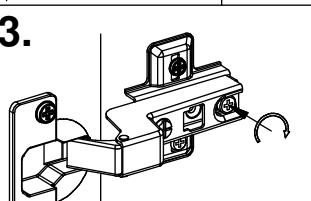

1.

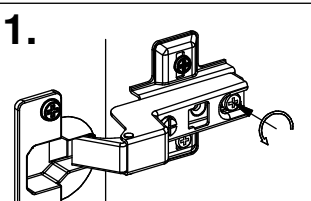

2.

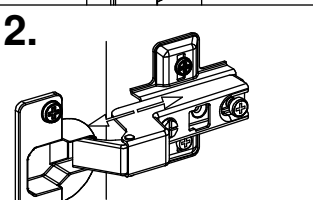

3.

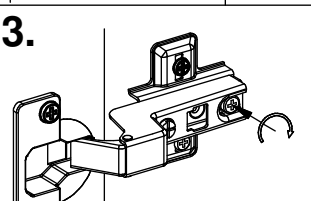

**RS ME**

Dostavljeni plastični tiplovi su namenjeni za ugradnju na standardan zid od cigle. Pre ugradnje korisnik je dužan da proveri da li dostavljeni tiplovi odgovaraju vrsti zida na koji je predviđena ugradnja. Ukoliko tiplovi ne odgovaraju zidu kupac je u obavezi da u specijalizovanoj radnji sam nabavi odgovarajuće tiplove.

**DE AT CH**

Die gelieferten Plastikdübel sind zum Einbau in die standardmäßige Ziegelwand bestimmt. Vor dem Einbau ist der Benutzer verpflichtet zu prüfen, ob die gelieferten Dübel der für den Einbau vorgesehenen Wandart entsprechen. Wenn die Dübel der Wand nicht entsprechen, ist der Kunde verpflichtet, im Fachhandel entsprechende Dübel selbst zu besorgen.

**ES**

Las clavijas plásticas que se incluyen están previstas para ser insertadas en un muro de ladrillo estándar. Antes de instalarlas, el usuario debe verificar si las clavijas proporcionadas son adecuadas para el tipo de muro previsto en que se propone insertarlas. Si las clavijas no son adecuadas para el muro, el comprador debe adquirir por sí mismo las clavijas correspondientes en una tienda especializada.

**RUS BLR**

Входящие в комплект поставки пластиковые дюбели предназначены для монтажа на стандартную кирпичную стену. До начала монтажа пользователь должен проверить соответствие поставленных дюбелей типу стены, на которую предусмотрен монтаж. Если дюбели не соответствуют типу стены, покупатель должен в обязательном порядке приобрести соответствующие дюбели в специализированном магазине.

**EL**

Οι πλαστικές βύδες που παρέχονται προορίζονται για ενσωμάτωση σε συνηθισμένο τοίχο από τούβλα. Πριν από την ενσωμάτωση, ο χρήστης οφείλει να ελέγξει εάν οι βύδες που παρέχονται αντιστοιχούν στον τύπο του τοίχου στον οποίο προβλέπεται η ενσωμάτωση. Εάν οι βύδες δεν ταιριάζουν στον τοίχο, ο αγοραστής υποχρεούται να προμηθευθεί κατάλληλες σε εξειδικευμένο κατάστημα.

**BG**

Доставените пластмасови дюбели са направени за вграждане в стандартна тухлена стена. Преди вграждането, ползувателят е длъжен да провери дали доставените дюбели съответстват на стената, за която са предвидени за вграждане. Ако дюбелите не съответстват на стената на купувача, то той задължително трябва да закупи съответни дюбели от специализирания магазин.

**SL**

Dostavljeni plastični nosilci so namenjeni za montažo na standardni zid iz opeke. Pred montažo je uporabnik dolžan preveriti, ali dostavljeni nosilci ustrezajo vrsti zidu, na katerem je predvidena montaža. V kolikor nosilci niso primerni, je kupec dolžan sam pri specializiranemu prodajalcu priskrbeti nosilce, ki ustrezajo montaži.

**MK**

Доставените пластични типли наменети се за прикачување на стандарден зид од цигла. Пред прикачувањето корисникот е должен да провери дали доставените типли одговараат на видот на зидот на кој е предвидено прикачувањето. Доколку типлите не одговараат купувачот е должен сам да набави во специјализирана продавница типли кои одговараат.

**PL**

Dołączone plastikowe kolki są przeznaczone do montażu na standardową ścianę z cegły. Przed zamontowaniem, użytkownik jest zobowiązany upewnić się, czy załączone kolki odpowiadają typowi ściany, na której jest przewidziany montaż. W przypadku gdy kolki nie są odpowiednie do typu ściany, na którą ma być zamontowany regał, użytkownik jest zobowiązany, aby samemu zaopatrzyć się w odpowiedni typ kołków w sklepie specjalistycznym.

**UK**

Delivered plastic plugs are intended for fitting on a standard brick wall. Before fitting, the buyer needs to check if the delivered plugs are suitable for the wall they are foreseen for. If the plugs are not suitable for the wall, buyers have to visit a specialized store and get suitable plugs by themselves.

**IT CH**

I tasselli di plastica consegnati sono destinati al montaggio su un muro di mattoni standard. Prima del loro montaggio, l'acquirente deve controllare se i tasselli forniti sono adatti per la parete su cui si prevede di installarli. Se i tasselli non sono adatti per questo tipo di parete, l'acquirente è tenuto ad acquistare i tasselli adeguati presso un negozio specializzato.

**FR CH**

Les chevilles en plastique fournies sont conçues à l'installation sur le mur standard en briques. Avant l'installation, l'utilisateur est obligé à vérifier si les chevilles fournies correspondent bien au type de mur prévu pour l'installation. Si les chevilles ne correspondent pas bien au mur, l'acheteur est obligé à assurer lui-même les chevilles correspondantes dans un magasin spécialisé.

**CZ SK**

Dodané plastové hmoždinky jsou určeny pro montáž na standardní cihlovou stěnu. Před začátkem montáže, kupující je povinnen dohlédnout na správnost typu dodaných hmoždinek, vzhledem na typ stěny určené k montáži. Pokud hmoždinky dodané výrobcem neodpovídají typu stěny určené k montáži, kupující je povinnen pořídit si správný typ ve specializované prodejně.

**RO**

Tiplurile din plastic transmise sunt prevăzute exclusiv pentru pereții standard din cărămidă. Înainte de instalare beneficiarul este obligat să verifice dacă tiplurile transmise corespund peretelui pe care se prevede instalarea. În cazul în care tiplurile nu corespund peretelui, cumpărătorul este obligat să achiziționeze singur tiplurile corespunzătoare din magazinele specializate.

**HR BIH**

Dostavljeni plastični tiplovi su namijenjeni za ugradnju na standardan zid od cigle. Prije ugradnje korisnik je dužan da provjeri da li dostavljeni tiplovi odgovaraju vrsti zida na koji je predviđena ugradnja. Ukoliko tiplovi ne odgovaraju zidu kupac je u obavezi da u specijaliziranoj radnji sam nabavi odgovarajuće tiplove.

**HU**

A kézbesített műanyag tiplik standard téglafalra való beépítésre szolgálnak. Beépítés előtt a felhasználónak kötelees leellenőrizni, hogy a tiplik megfelelőek-e a falajtájának, amelyre a beépítést szánták. Ha a tiplik nem felelnek meg, a vásárló köteles a megfelelőket szaküzletben beszerezni.

**AL**

Ankorat e dhëna plastike janë të dizajnuara për instalim në mur standard me tulla. Para instalimit përdoruesi duhet të verifikojë nëse ankorat e dërguara iu përshtaten llojit të murit në të cilin është parashikuar të bëhet instalimi. Nëse ankorat nuk iu përshtaten murit, blerësi është i obliguar që vetë të blejë ankorat e duhura në shitoren e specializuar.