

UPUTSTVO ZA MONTIRANJE
ASSEMBLING INSTRUCTION
MONTAGEANLEITUNG
INSTRUCTIONS D'ASSEMBLAGE
INSTRUCCIONES DE MONTAJE

ISTRUZIONI PER L'INSTALLAZIONE
ИНСТРУКЦИЯ ПО МОНТАЖУ
MONTÁŽNÍ NÁVOD
ΟΔΗΓΙΕΣ ΣΥΝΑΡΜΟΛΟΓΗΣΗΣ
INSTRUCȚIUNI DE MONTAJ

ИНСТРУКЦИЯ ЗА МОНТАЖ
SZERELÉSI UTASÍTÁS
NAVODILA ZA MONTAŽO
UPUTE ZA MONTAŽU
UPUTSTVO ZA MONTIRANJE

УПАТСТВО ЗА МОНТИРАЊЕ
UDHËZIMET PËR MONTIM
INSTRUKCJA MONTAŻU

LOUIS 2K VS1

CODE: UP00515

Version: 01-31012018

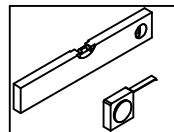
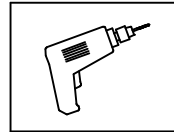
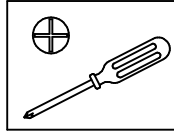
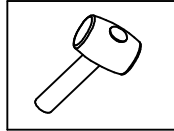
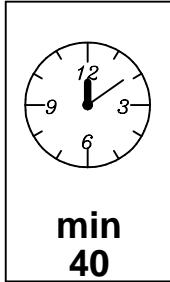
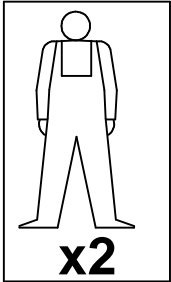

RS ME PRE POČETKA MONTIRANJA OBAVEZNO PROČITAJTE UPUTSTVO ZA MONTAŽU / **UK** BEFORE STARTING, REFER TO THE ASSEMBLING ADVICE IN ANNEX / **DE AT CH** VOR DER MONTAGE BITTE BEILIEGENDE ANWEISUNGEN LESEN / **FR CH** AVANT LE DÉBUT DE L'ASSEMBLAGE, S'IL VOUS PLAÎT, LISEZ L'INSTRUCTION D'ASSEMBLAGE / **ES** ANTES DE EMPEZAR EL MONTAJE, LEER CUIDADOSAMENTE LAS INSTRUCCIONES DEL ANEXO / **IT CH** PRIMA DI INIZIARE L'INSTALLAZIONE SI RACCOMANDA DI LEGGERE LE ISTRUZIONI DI INSTALLAZIONE / **RUS** ДО НАЧАЛА МОНТАЖА ОЗНАКОМЬТЕСЬ С ИНСТРУКЦИЕЙ / **CZ** SEZNAMTE SE S NÁVODEM PŘED MONTÁŽÍ NÁBYTKU / **EL** ΠΡΙΝ ΞΕΚΙΝΗΣΕΤΕ ΤΗ ΣΥΝΑΡΜΟΛΟΓΗΣΗ, ΟΠΩΣΔΗΠΟΤΕ ΔΙΑΒΑΣΤΕ ΤΙΣ ΟΔΗΓΙΕΣ ΣΥΝΑΡΜΟΛΟΓΗΣΗΣ / **RO** ÎNAINTE DE ÎNCERPEREA MONTAJULUI ESTE OBLIGATORIE CĂTIREA INSTRUCȚIUNILOR / **BG** ПРЕДИ МОНТИРАНЕ НЕ ЗАБРАВЯЙТЕ ДА СЪ ЧЕТЕ ИНСТРУКЦИИ ЗА МОНТАЖ / **HU** SZERELÉS ELŐTT OKVETLENŰL OLVASSA EL A HASZNÁLATI UTASÍTÁST / **SL** PRED ZAČETKOM MONTAŽE OBVEZNO PREBERITE NAVODILA / **HR** PRIJE MONTAŽE UPOZNATI SE SA UPUTSTVOM / **BIH** PRE POČETKA MONTIRANJA OBAVEZNO PROČITAJTE UPUTSTVO ZA MONTAŽU / **MK** ПРЕД ПОЧЕТОК НА МОНТИРАЊЕ ЗАДОЛЖИТЕЛНО ДА СЕ ПРОЧИТА УПАТСТВОТО ЗА МОНТИРАЊЕ / **AL** PARA FILLIMIT TË MONTIMIT LEXONI PATJETËR UDHËZIMIN PËR MONTIM / **PL** PRZED ROZPOCZĘCIEM MONTAŻU PROSZĘ ZAPOZNAĆ SIĘ Z INSTRUKCJĄ

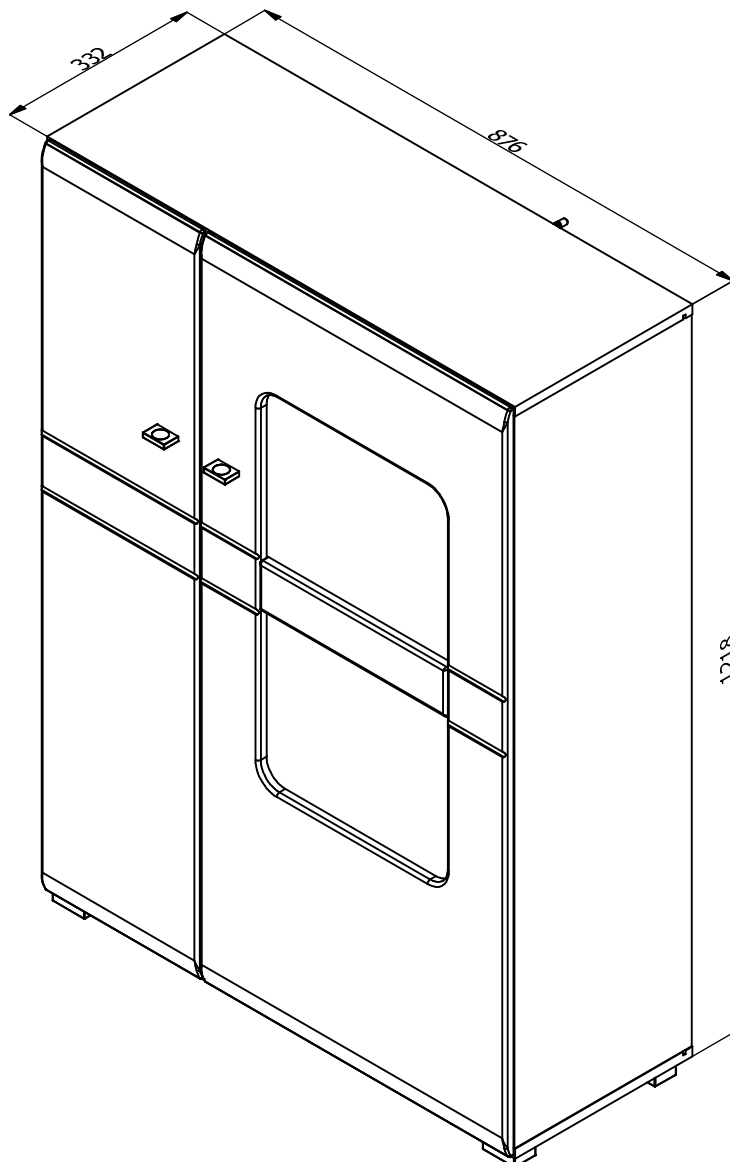



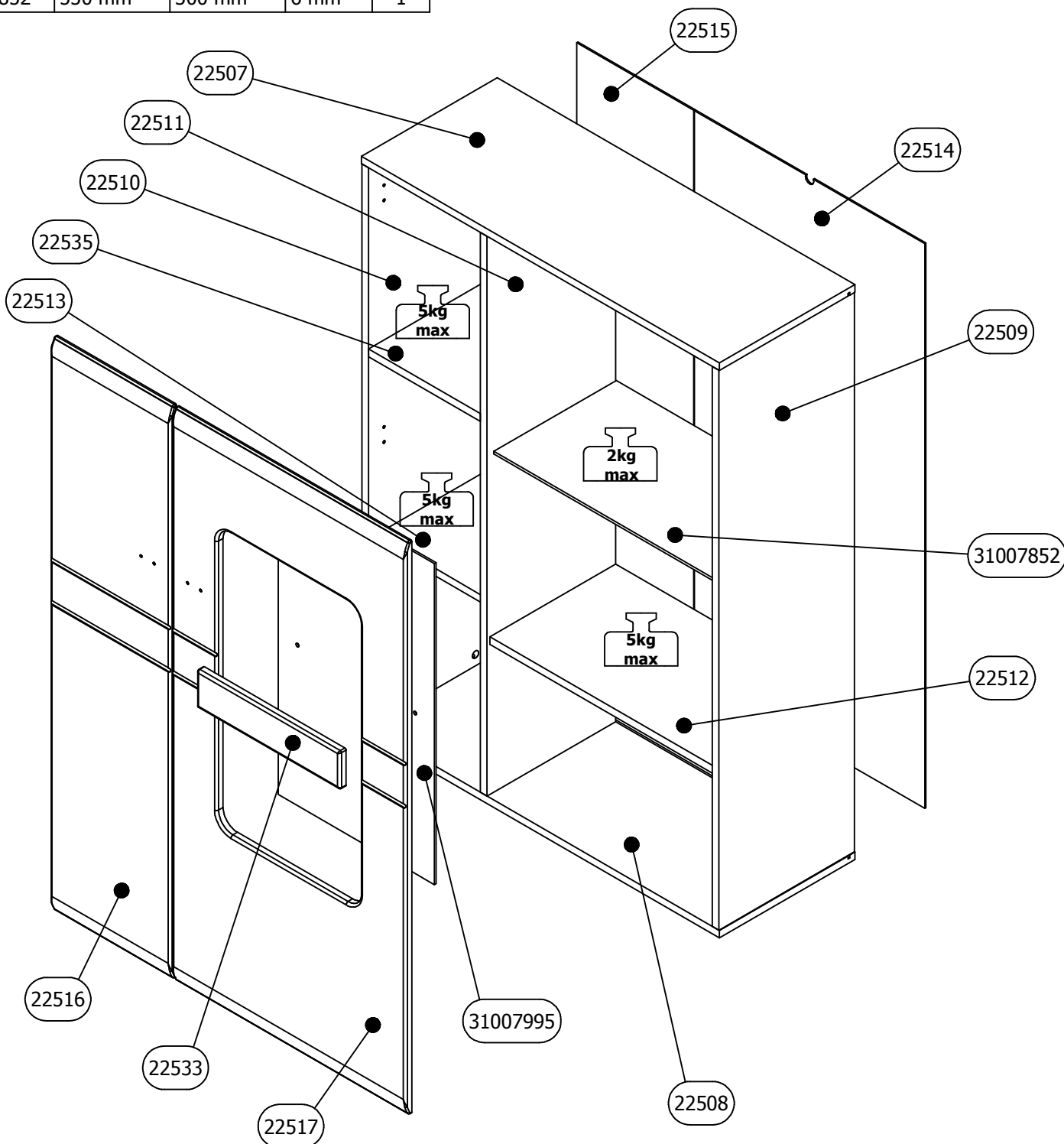



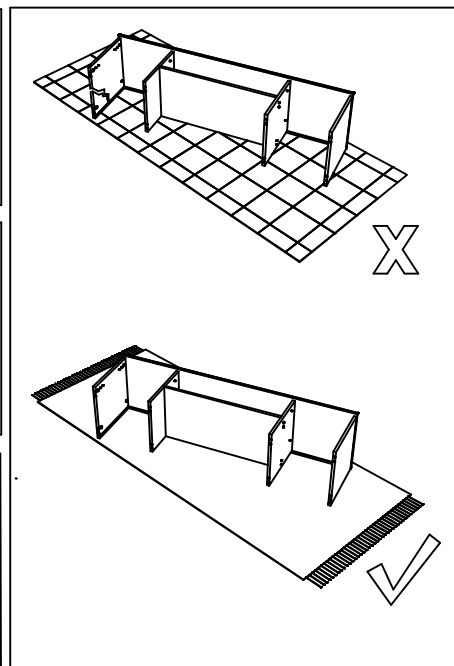
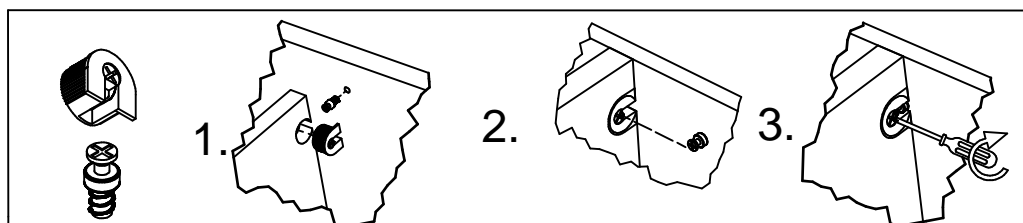
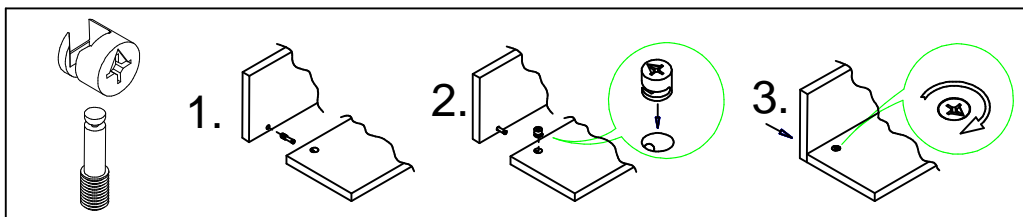
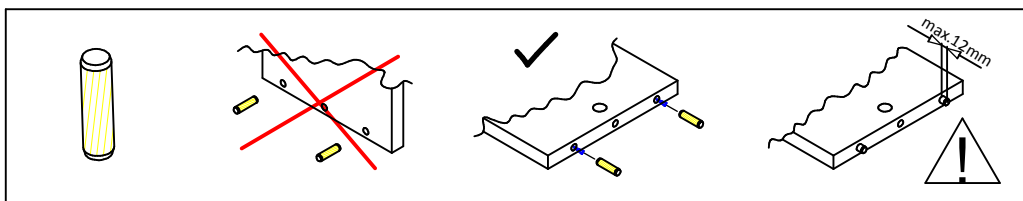

























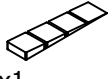

22509	1186 mm	332 mm	16 mm	1
22507	876 mm	332 mm	16 mm	1
22508	876 mm	332 mm	16 mm	1
22510	1186 mm	332 mm	16 mm	1
22516	1214 mm	294 mm	16 mm	1
22517	1214 mm	572 mm	16 mm	1
22511	1186 mm	315 mm	16 mm	1
22512	552 mm	308 mm	16 mm	1
22513	273 mm	296 mm	16 mm	1
22514	1196 mm	564 mm	3 mm	1
22515	1196 mm	286 mm	3 mm	1
31007995	680 mm	382 mm	4 mm	1
22535	274 mm	315 mm	16 mm	1
22533	350 mm	80 mm	16 mm	1
31007852	550 mm	300 mm	6 mm	1









RS ME 1. Montažu obavljati na čistoj i mekoj podlozi (karton, tkanina...) 2. Da bi izbegli oštećenja elemenata pridržavati se datih instrukcija. 3. Prilikom prijave reklamacije koristiti date oznake elemenata.	FR CH 1. Effectuer l'assemblage sur une surface propre et douce (carton, tissu...) 2. Afin d'éviter l'endommagement des éléments, respectez les instructions données. 3. Lors de l'application de réclamation, utiliser les désignations données des éléments.
DE AT CH 1. Die Montage soll auf sauberer, weicher Fläche durchgeführt werden (Karton, Stoff) 2. Um die Beschädigung der Elemente zu vermeiden, befolgen Sie bitte die angegebenen Instruktionen 3. Bei Reklamationsmeldungen benutzen Sie bitte die angegebenen Kennzeichen der Elemente	UK 1. Assembly of the product should be done on a clean and soft surface (cardboard, fabric) 2. To prevent damage of the product, it is necessary to adhere to the assembly instructions 3. While reporting defective products, please quote codes in manual
ES 1. Realizar el montaje sobre una superficie limpia y suave (cartón, paño) 2. Para evitar daños del producto, atenerse a las instrucciones de montaje 3. Para reportar productos defectuosos, refiérase por favor a los códigos del manual	IT CH 1. Eseguire l'installazione su una base morbida (cartone, tessuto). 2. Seguire le istruzioni per evitare di causare danni agli elementi. 3. In caso della presentazione di reclamo si utilizzano relative indicazioni degli elementi.
RO 1. Montarea se efectueaza pe o suprafata moale și curată (carton, material..) 2. Respectați instrucțiunile pentru a evita deteriorarea pieselor 3. La transmiterea reclamațiilor a se folosi inscripțiile date ale pieselor	CZ SK 1. Montáž provádět na čistém a měkkém podkladu (lepenka, látka) 2. Dodržujte příložené instrukce, abyste předešli poškození součástí 3. Při reklamaci používejte příložené označení element
EL 1. Η συναρμολόγηση του προϊόντος πρέπει να γίνει σε καθαρή και μαλακή επιφάνεια (χαρτόνι, ύφασμα). 2. Για να μην φθαρούν τα στοιχεία, συμμορφωθείτε με τις οδηγίες που παρέχονται. 3. Κατά τη δήλωση ελαττωματικού προϊόντος, αναφέρετε τους κώδικες των στοιχείων όπως αναφέρονται στο εγχειρίδιο.	RUS BLR 1. Монтаж изделия выполнять на чистой и мягкой поверхности (картон, ткань) 2. Для предотвращения порчи изделий необходимо придерживаться правил монтажа 3. В случае предъявления претензии использовать данные обозначения элементов.
BG 1. Монтажът трябва да бъде извършен върху чиста и мека основа /karton, тъкан/ 2. За да избегнете оцетяване на елементи, спазвайте дадените инструкции 3. При наличие на рекламация, използвайте дадените кодове на елементи	HU 1. A szerelés tisztaság és puha felületen (karton, anyag) kell végrehajtani. 2. Károsodásnak elkerülése érdekében, tartsa be a megadott utasításokat. 3. Reklamáció esetén hivatkozzon a bútor alkatrészein megadott jelekre.
SL 1. Montažo opravimo na čisti in mehki podlogi (karton, tkanina) 2. Da bi se ozognili poškodbam elementov, upoštevajte navodila. 3. Pri reklamaciji uporabimo oznake elementov	BIH HR 1. Montažu obavljati na čistoj i mekoj podlozi (karton, tkanina) 2. Da bi izbegli oštećenja elemenata pridržavati se datih instrukcija 3. Prilikom prijave reklamacije koristiti date oznake elemenata
MK 1. Монтажа да се врши на чиста и мека подлога (karton, ткаенина) 2. За да се избегне оштетување на елементите придржувајте се на дадените инструкции 3. За пријава на рекламации користете ги дадените ознаки на елементите	AL 1. Montimi të bëhet në sipërfaqe të pastër dhe të butë (karton, pëlhurë) 2. Që t'u shmangeni dëmtimit të elementeve, përmbahuni instrukcioneve të dhëna 3. Me rastin e reklamimit përdorni shenjat e dhëna të elementit
PL 1. Montować należy na czystej i miękkiej powierzchni (karton, tkanina) 2. Aby uniknąć uszkodzenia elementów należy postępować ściśle według instrukcji. 3. Przy zgłaszaniu reklamacji należy posługiwać się załączonymi oznaczeniami elementów.	HR 1. Pažljivo pročitajte upute za montažu 2. Pripremite sve dijelove namještaja 3. Prikupite i provjerite okove za montažu 4. Pripremite potreban alat 5. Pripremite prostor za montažu 6. Počnite montirati 7. Sačuvajte ove ove upute 8. Proizvod je namjenjen isključivo za kućnu uporabu

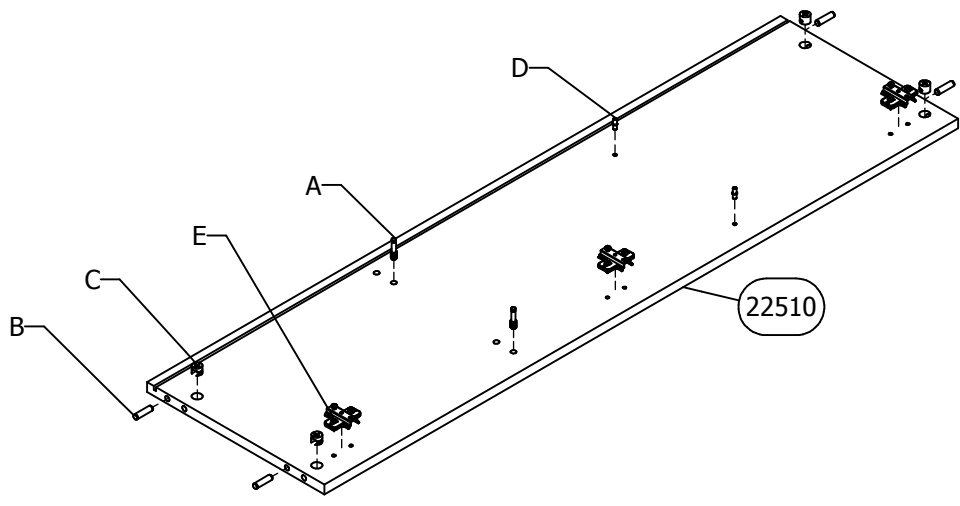

A x20 	B Ø8x30 x20 	C x20 	D x4 	E x6 	F x20 	G x4 	H x6 	I x2 	J M4x22 x4 
K x2 	L x2 	M M4x12 x2 	N x10 	O 3x16 x10 	P 3x25 x4 	Q x4 	R x12 	S x5 	T 4x30 x10 
U x1 	V x1 	W 6x60 x1 	X 4x16 x2 	Y x4 	Z x1 	Aa 	Ab 	Ac 	Ad 

1	B x 4 Ø8x30 	C x 4 	A x 2 	D x 2 	E x 3 
----------	---	--	--	--	--



2	B x 4 Ø8x30 	C x 4 	A x 2 	G x 2 	E x 3 
----------	---	--	--	--	--

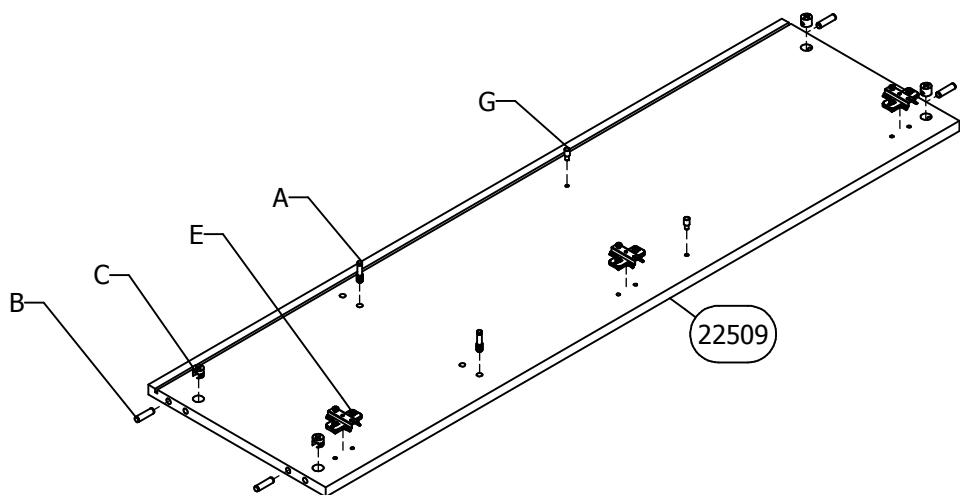

3

B x 4

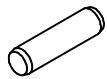

Ø8x30

C x 4



A x 4



D x 2

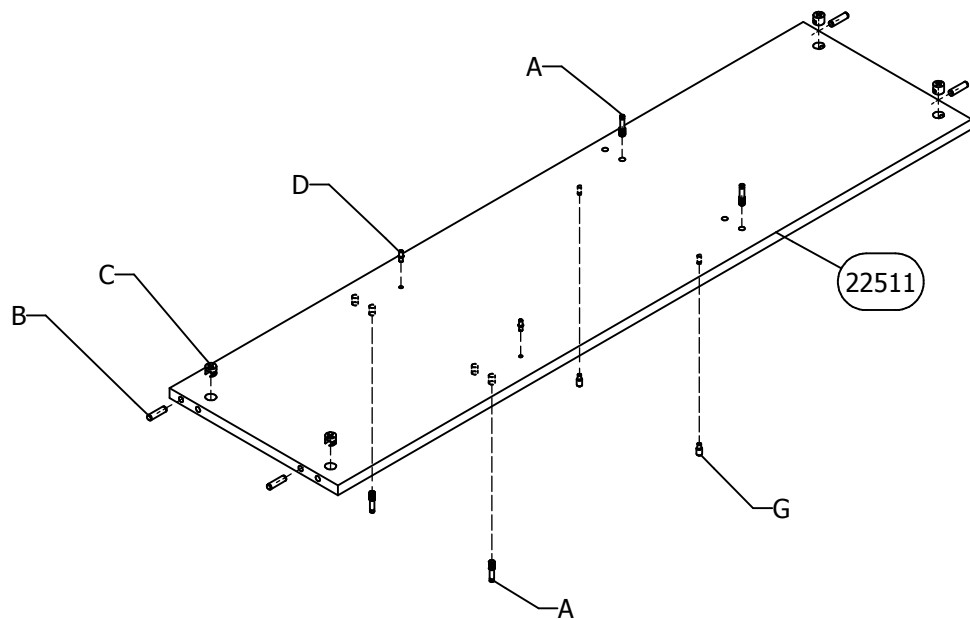

G x 2

**4**

B x 4

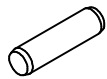

Ø8x30

C x 4

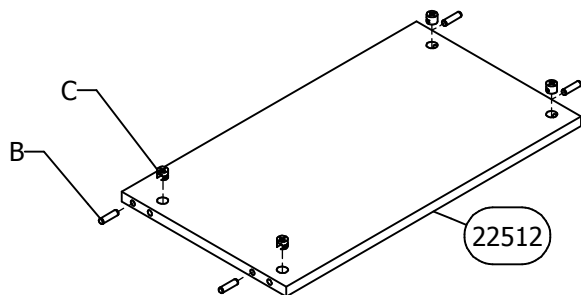
**5**

B x 4

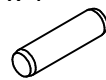

Ø8x30

C x 4

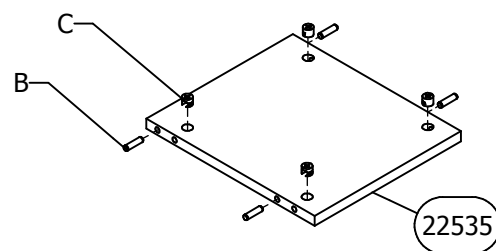
**6**

A x 6

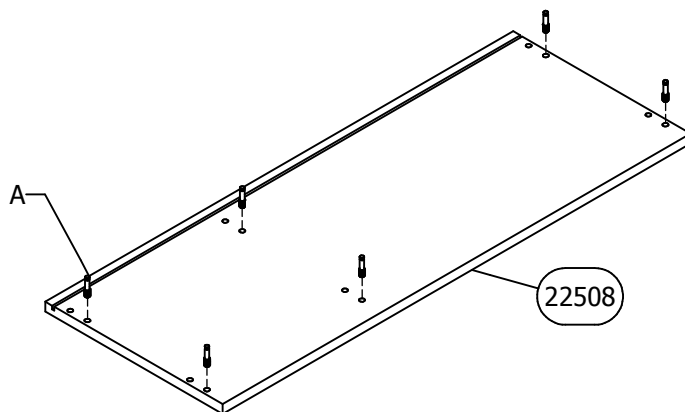

7

A x 6

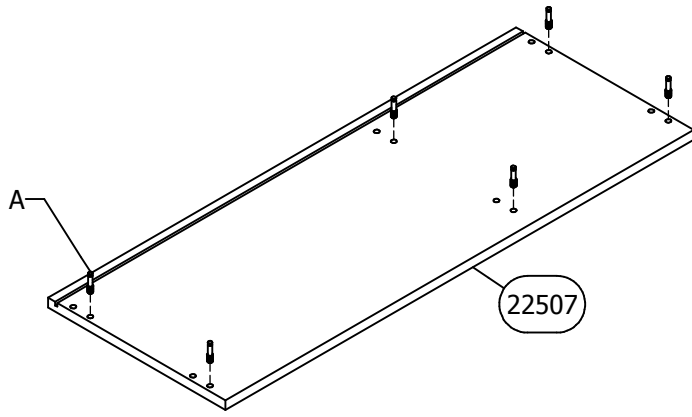

8

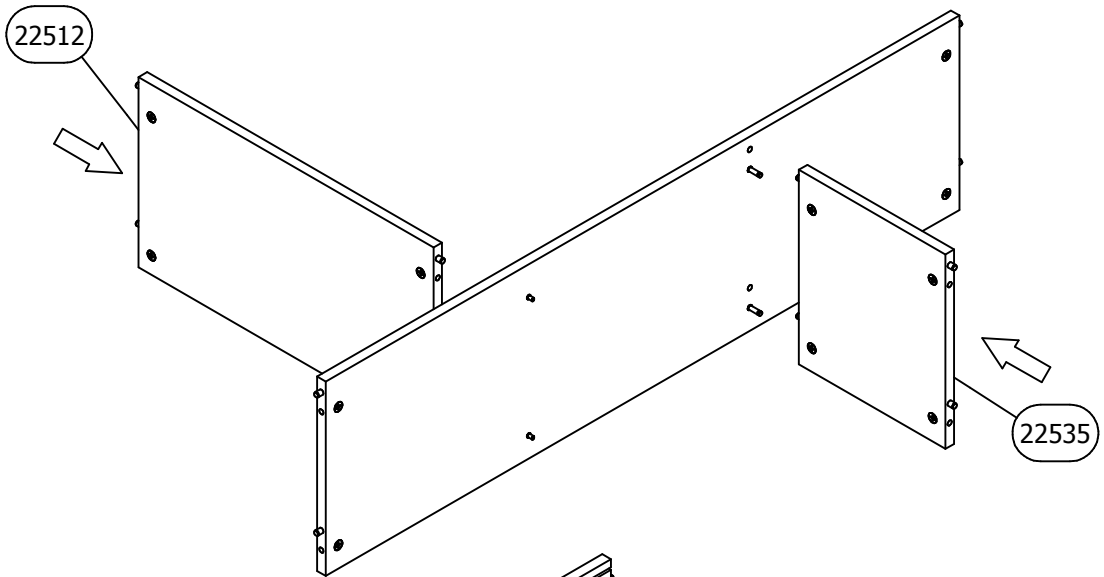

9

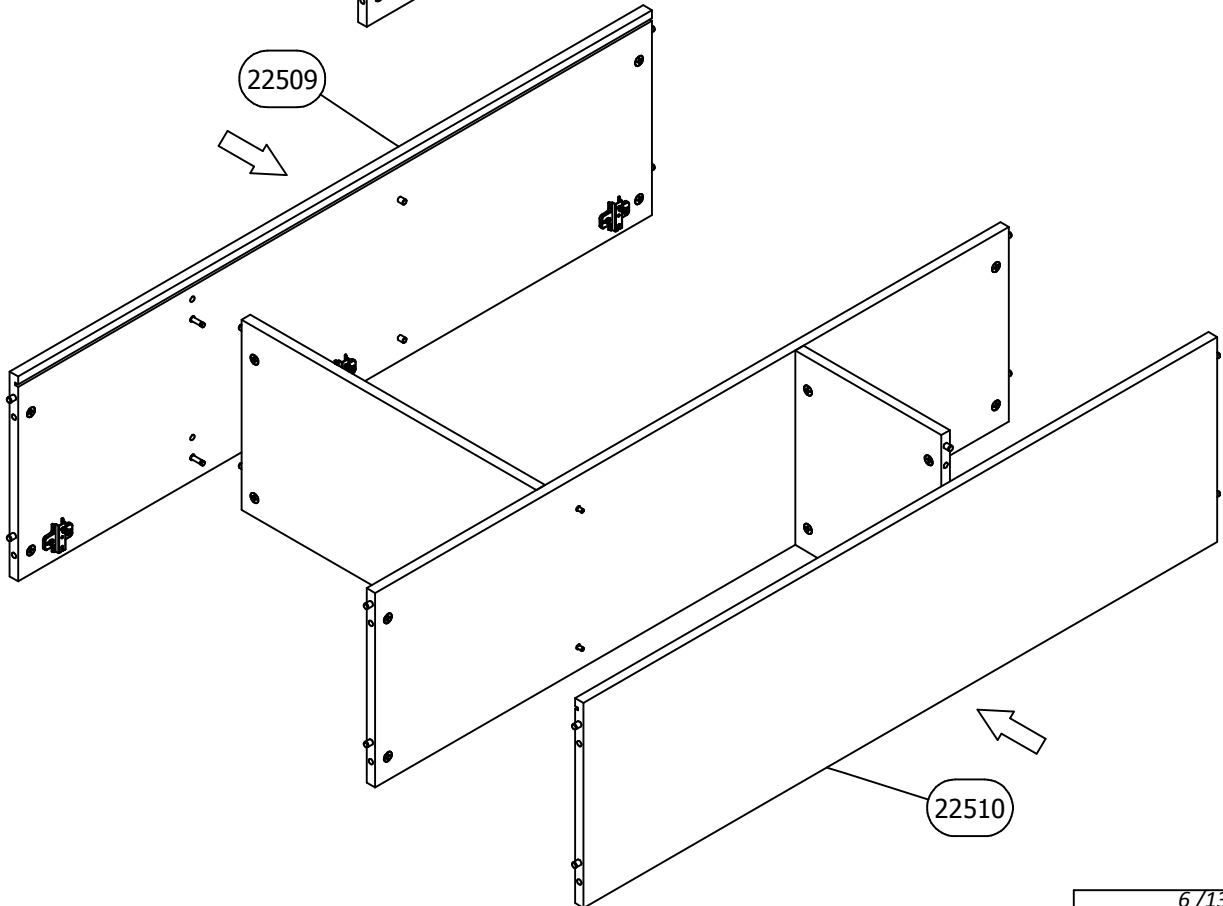

10

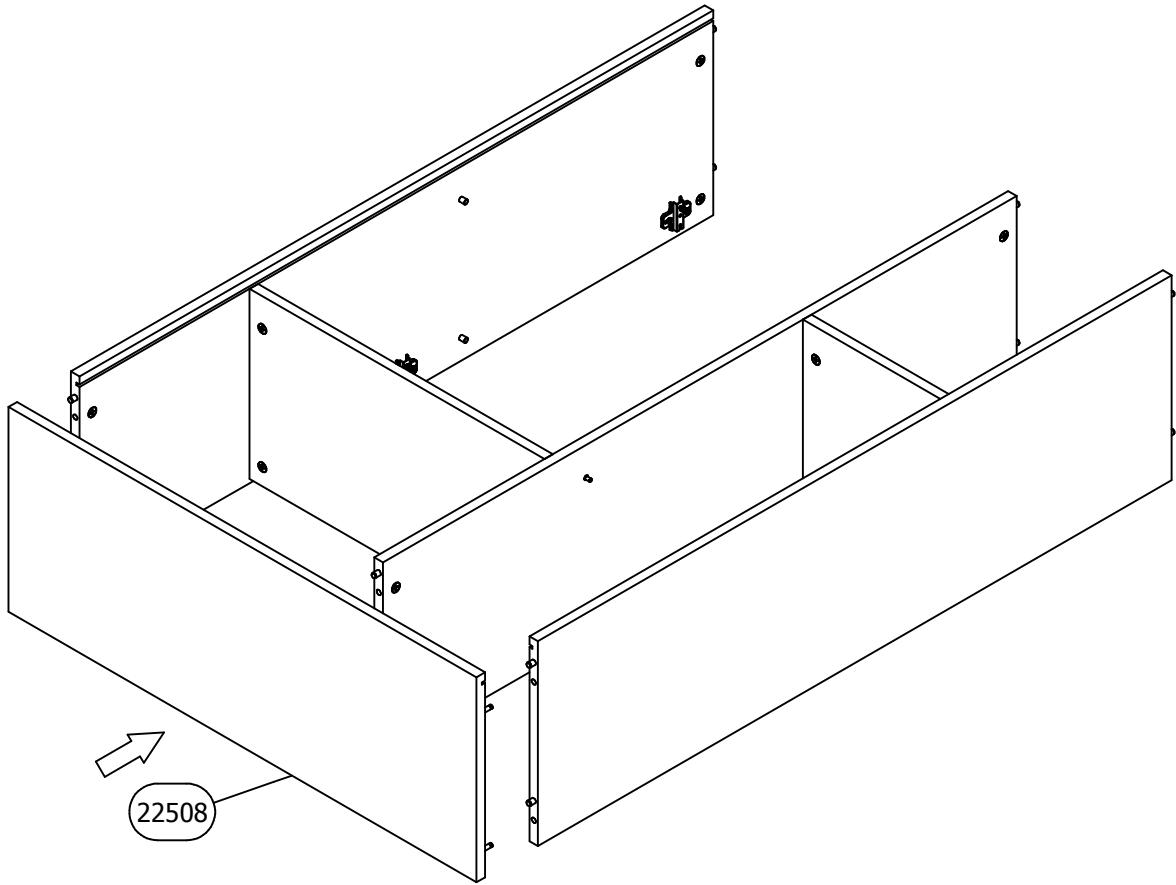

11

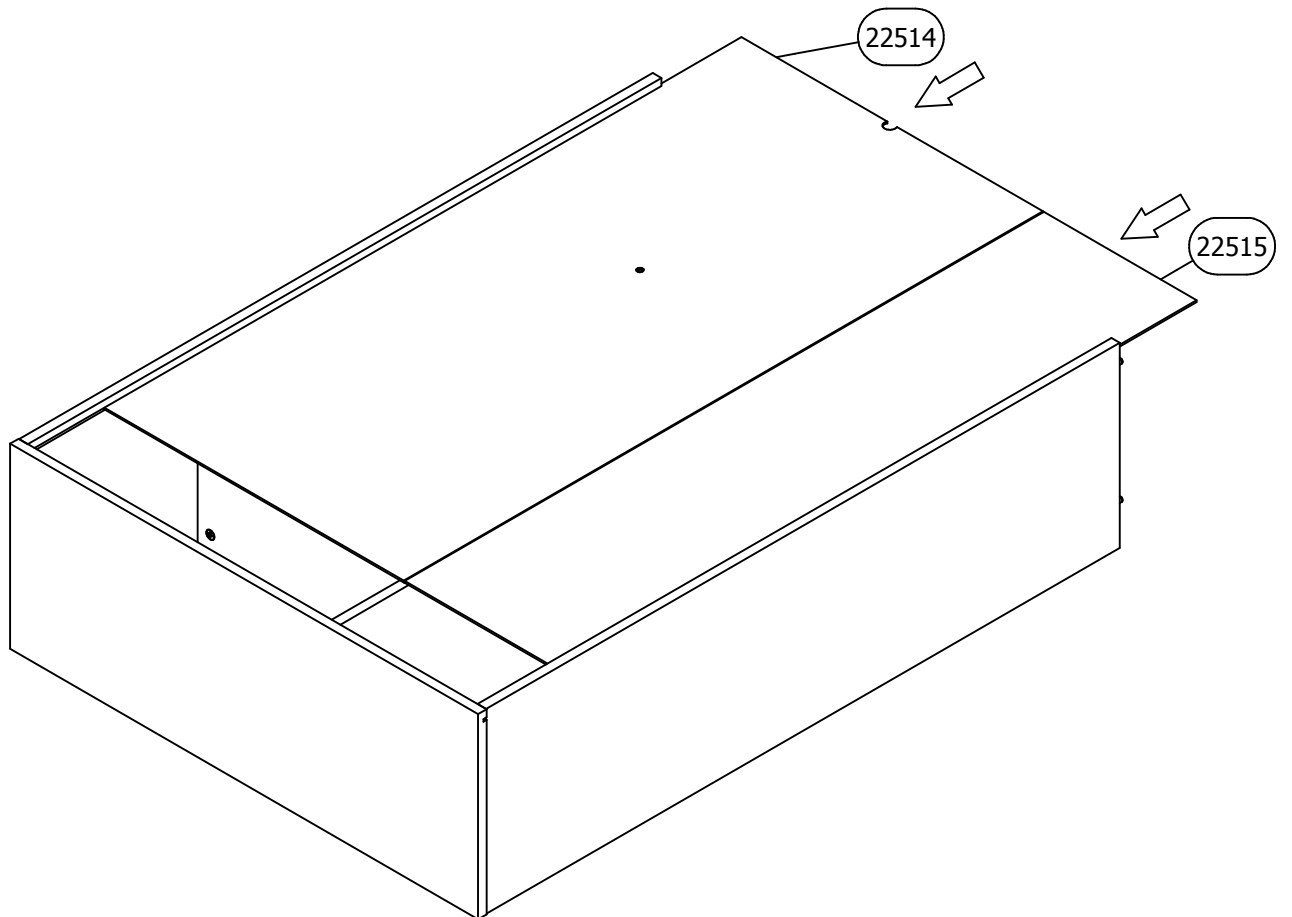

12

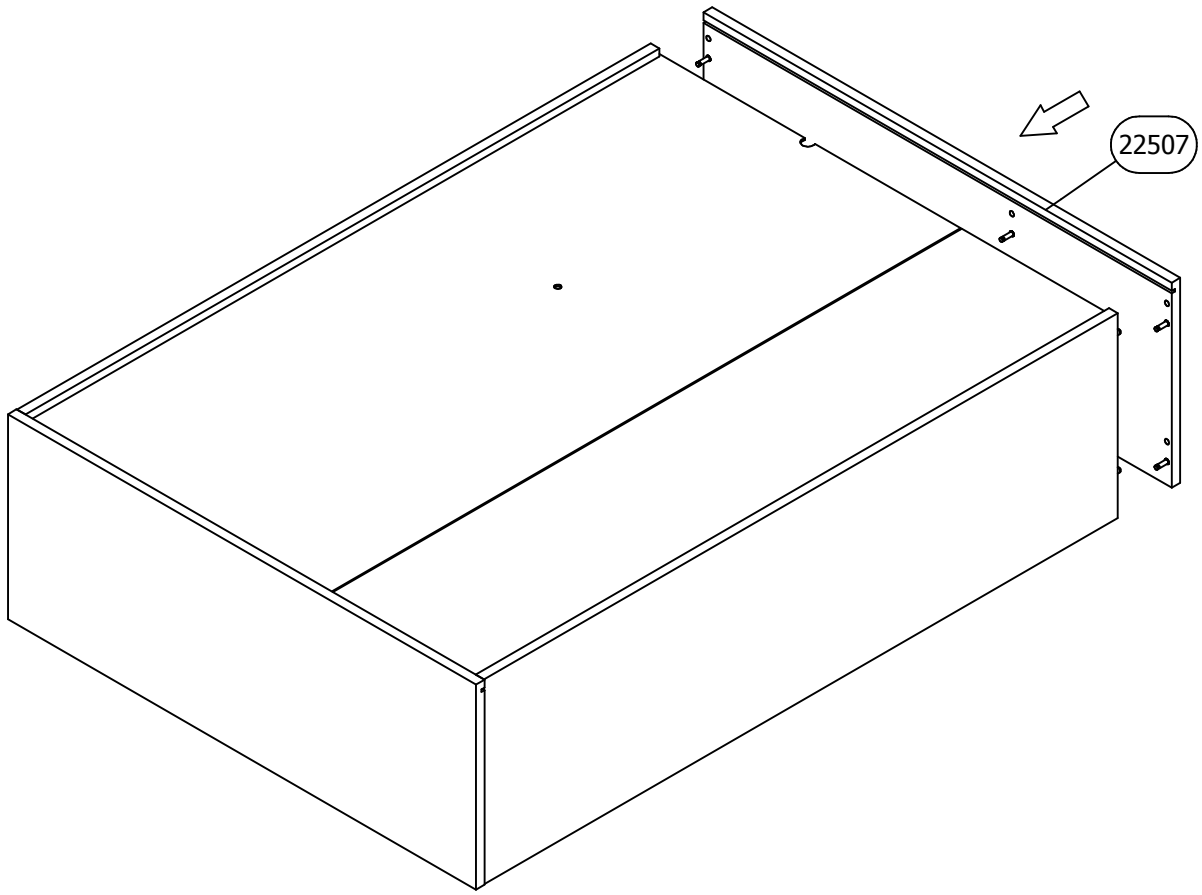

13

!
A1=A2

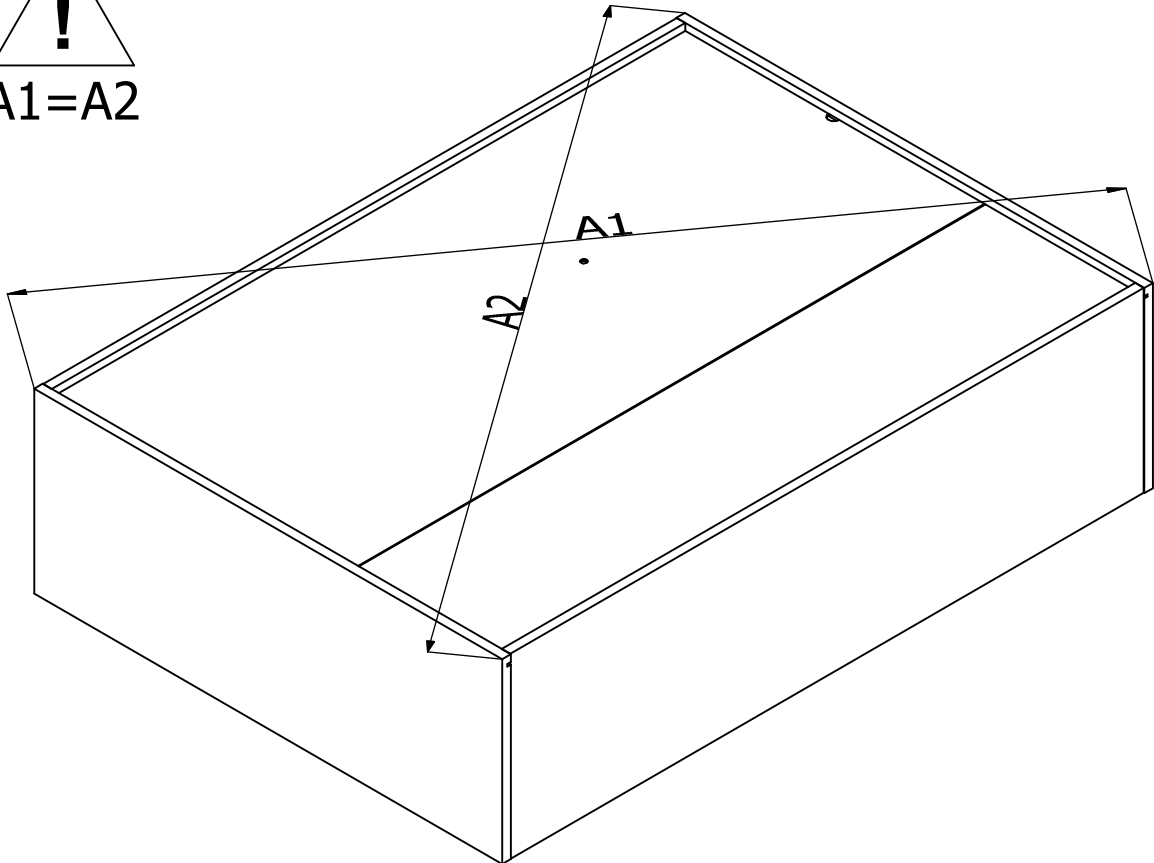

14

P x 4

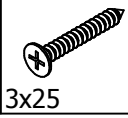

Q x 4



R x 12



S x 5



T x 10

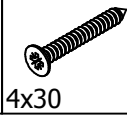

3x25

4x30

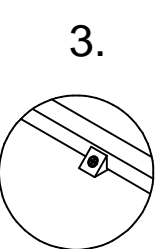
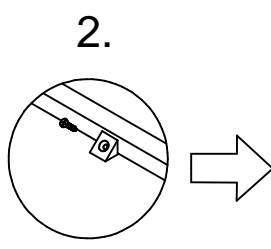
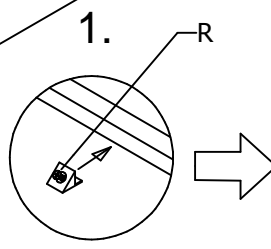
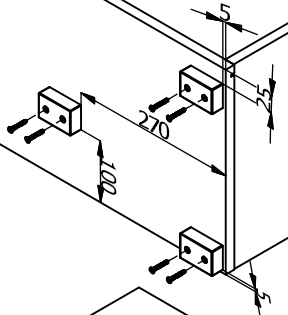
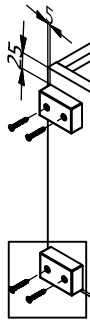
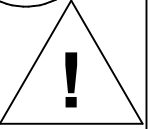
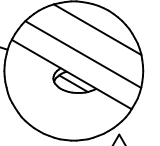
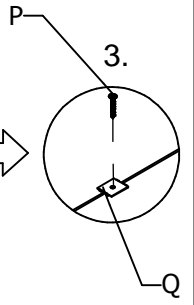
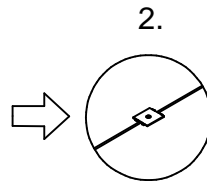
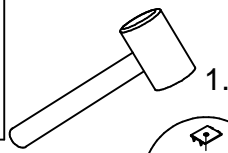
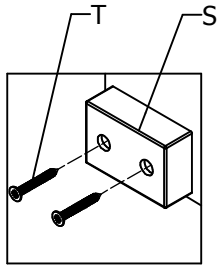

15

F x 20

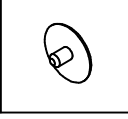

Y x 4

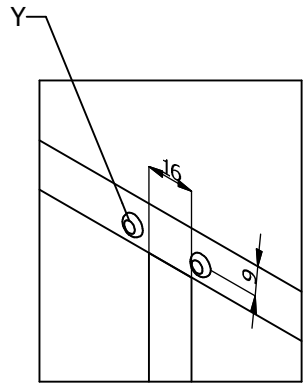
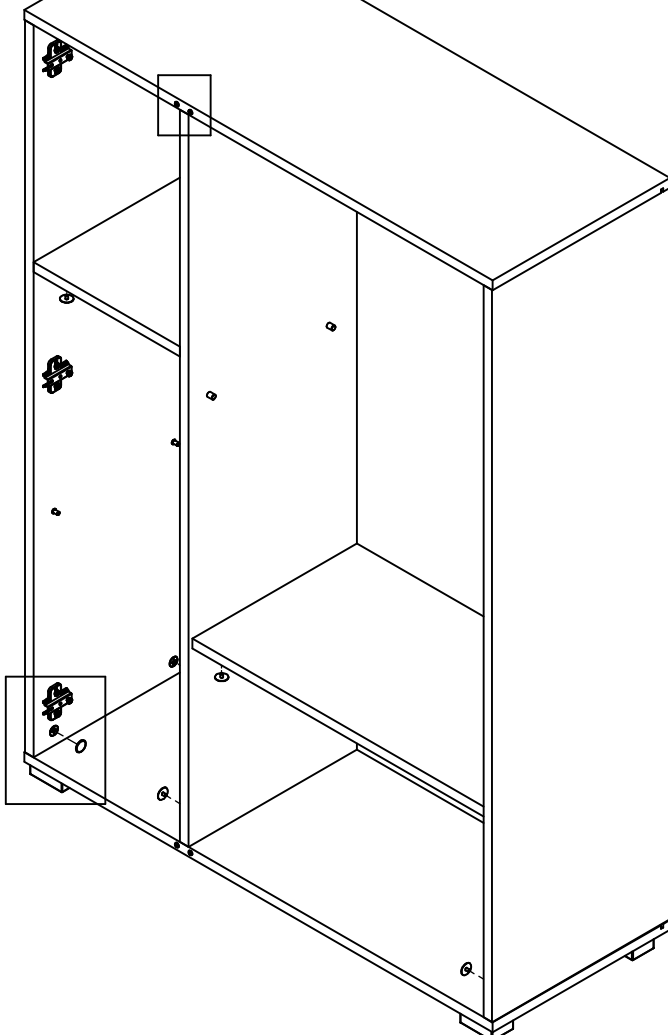
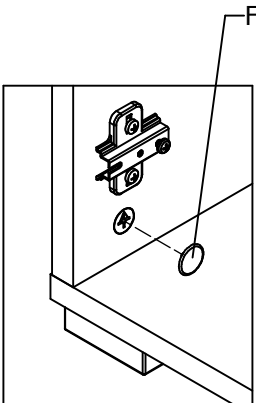
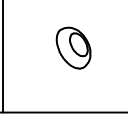

16

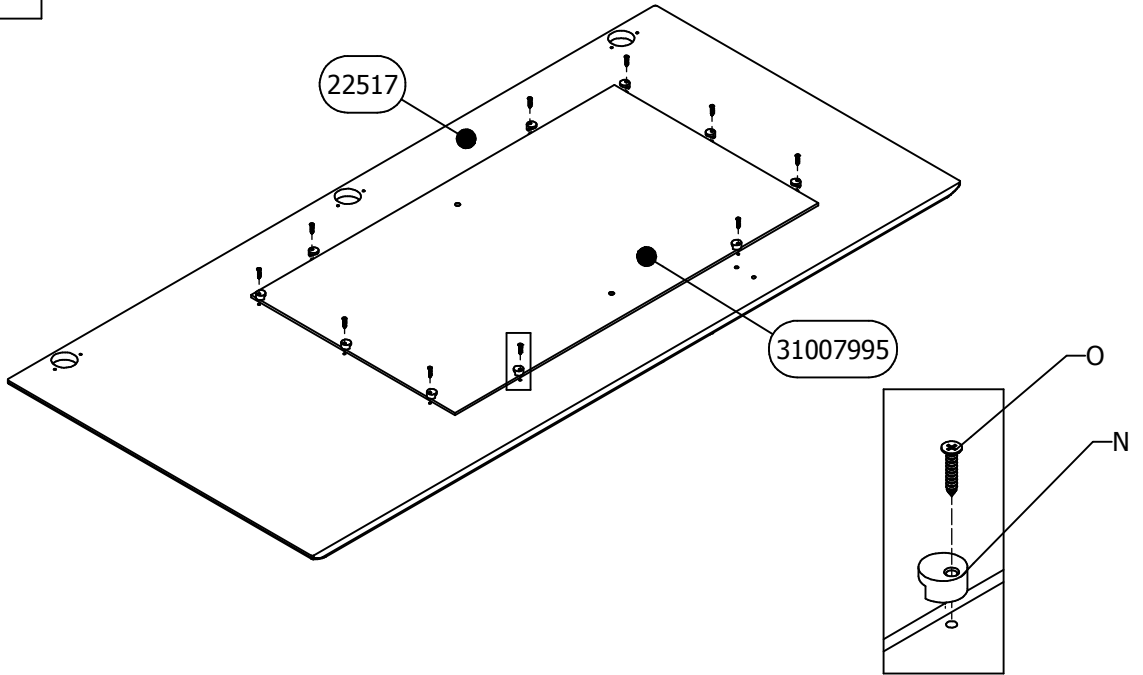
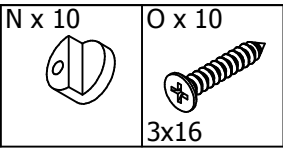

17

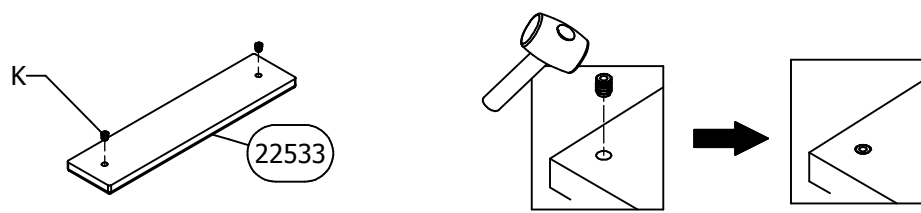
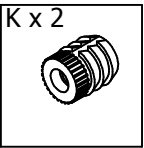

18

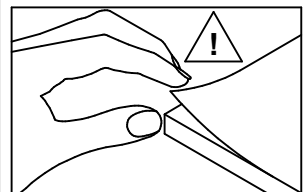
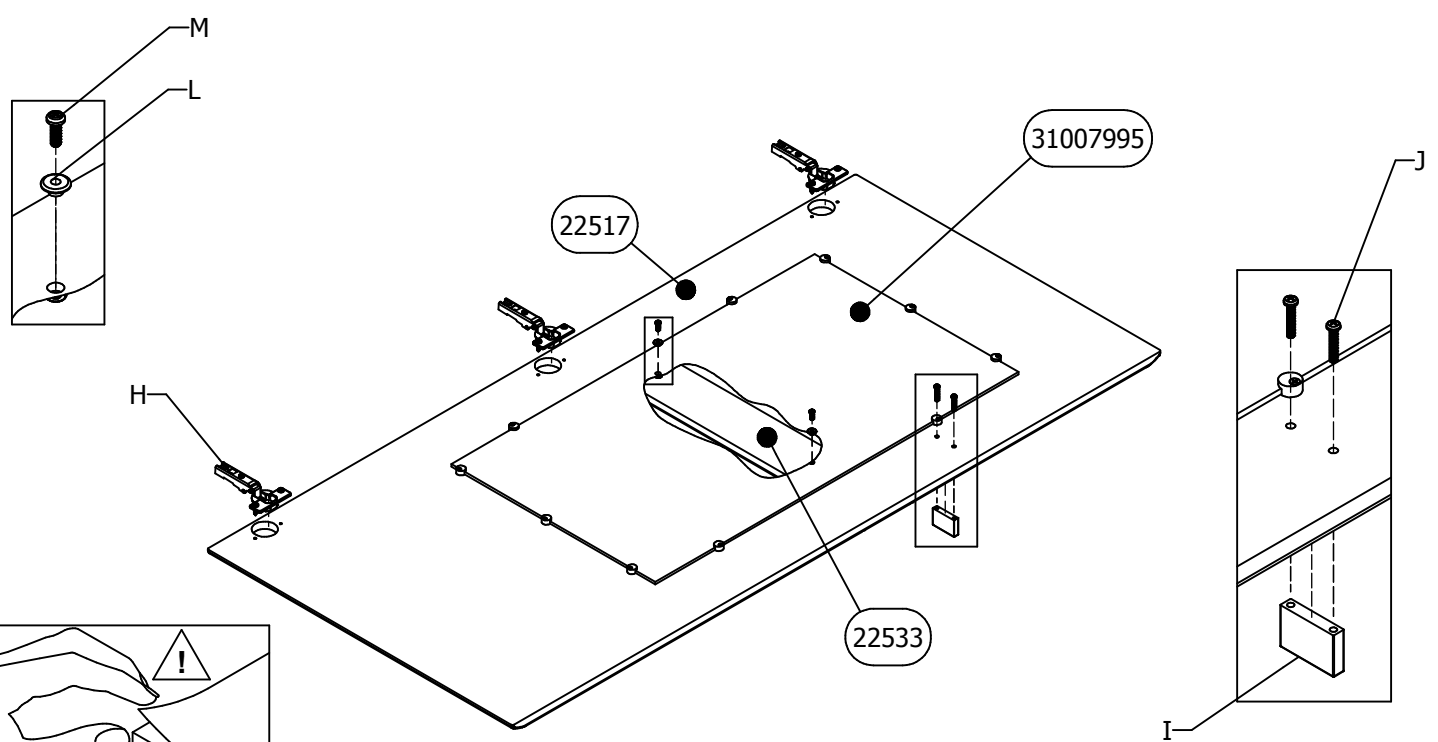
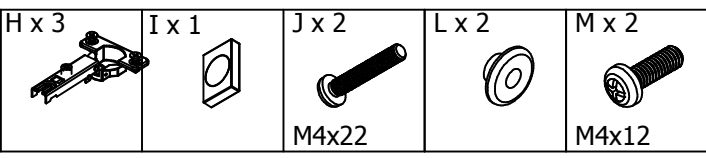

19

H x 3



I x 1



J x 2



M4x22

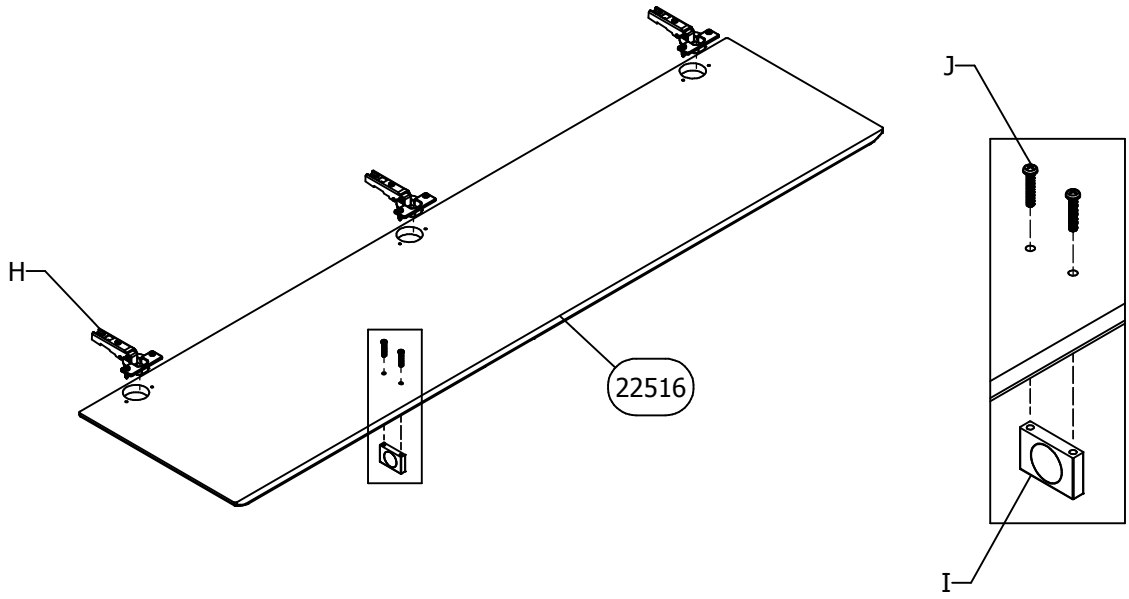

20

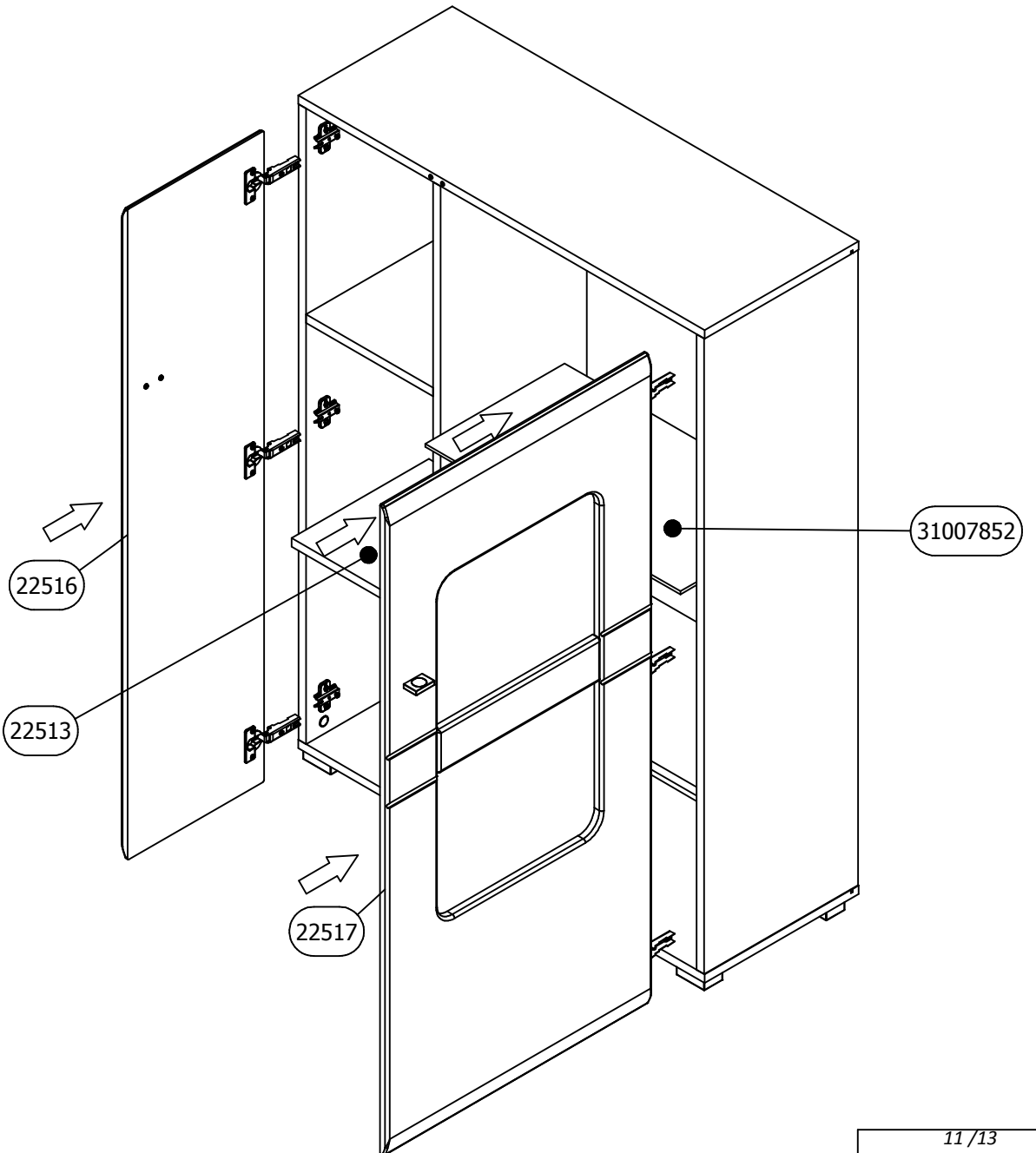

21

U x 1	V x 1	W x 1	X x 2	Z x 1
		6x60	4x16	

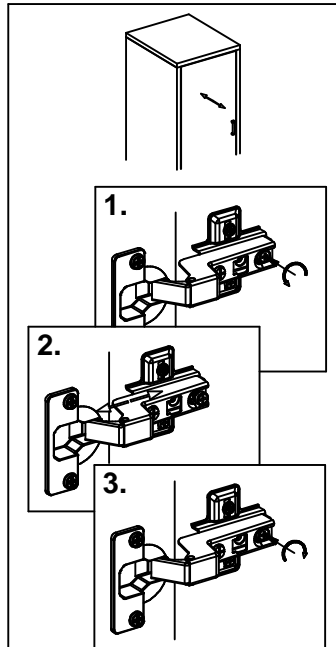
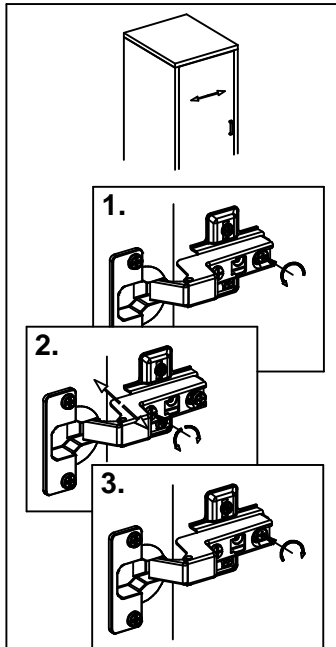
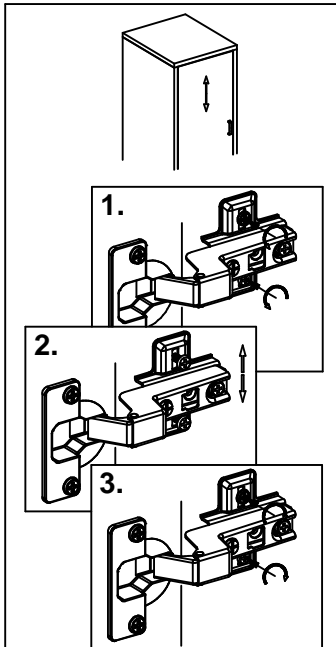
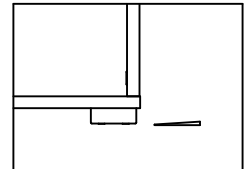
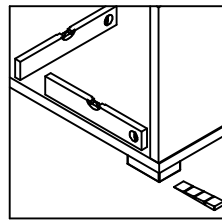
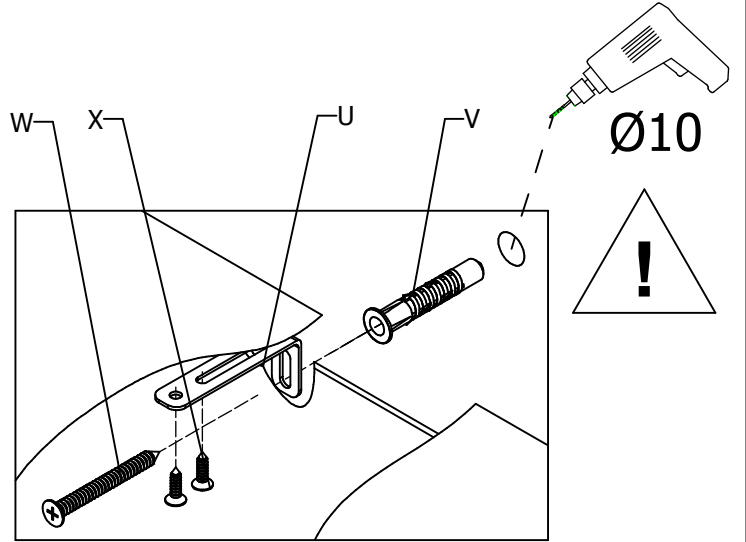
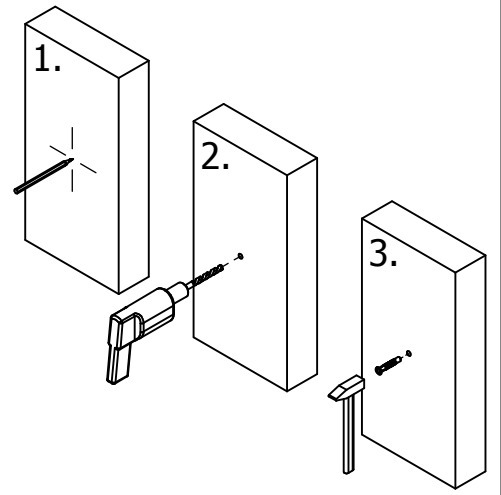
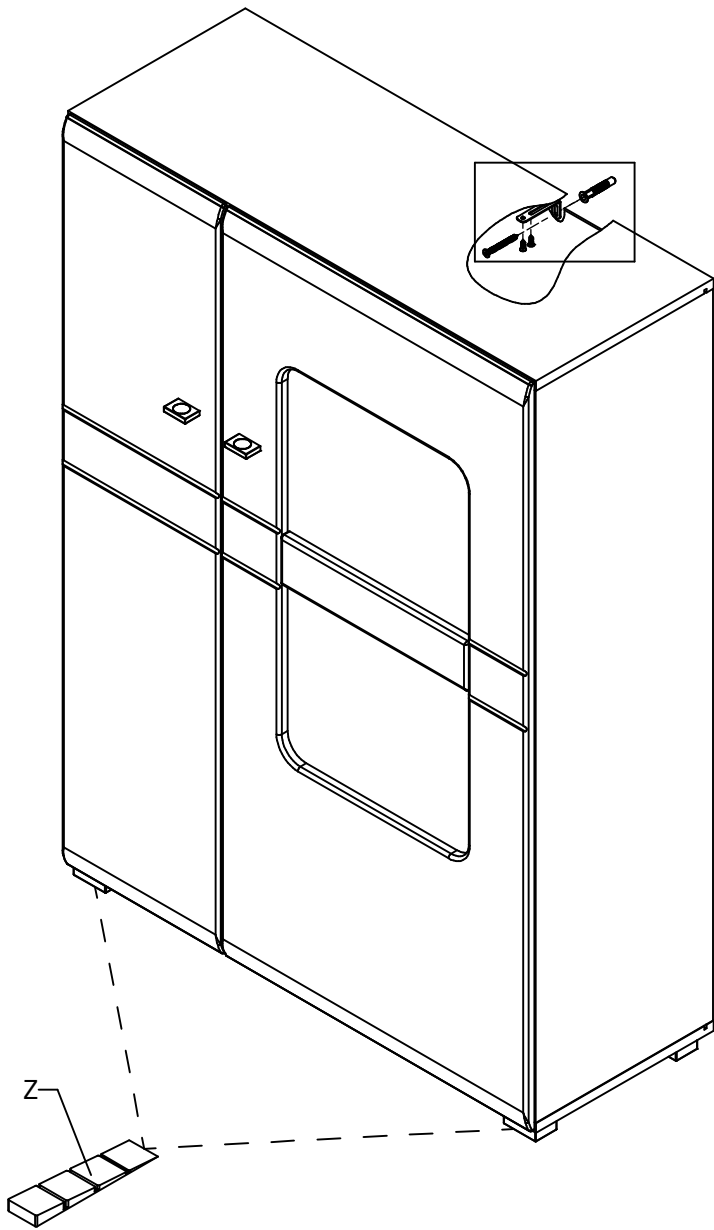

**RS ME**

Dostavljeni plastični tiplovi su namenjeni za ugradnju na standardan zid od cigle. Pre ugradnje korisnik je dužan da proveri da li dos tavljeni tiplovi odgovaraju vrsti zida na koji je predviđena ugradnja. Ukoliko tiplovi ne odgovaraju zidu kupac je u obavezi da u specijalizovanoj radnji sam nabavi odgovarajuće tiplove.

DE AT CH

Die gelieferten Plastikdübel sind zum Einbau in die standardmäßige Ziegelwand bestimmt. Vor dem Einbau ist der Benutzer verpflichtet zu prüfen, ob die gelieferten Dübel der für den Einbau vorgesehenen Wandart entsprechen. Wenn die Dübel der Wand nicht entsprechen, ist der Kunde verpflichtet, im Fachhandel entsprechende Dübel selbst zu besorgen.

ES

Las clavijas plásticas que se incluyen están previstas para ser insertadas en un muro de ladrillo estándar. Antes de instalarlas, el usuario debe verificar si las clavijas proporcionadas son adecuadas para el tipo de muro previsto en que se propone insertarlas. Si las clavijas no son adecuadas para el muro, el comprador debe adquirir por sí mismo las clavijas correspondientes en una tienda especializada.

RUS BLR

Входящие в комплект поставки пластиковые дюбели предназначены для монтажа на стандартную кирпичную стену. До начала монтажа пользователь должен проверить соответствие поставленных дюбелей типу стены, на которую предусмотрен монтаж. Если дюбели не соответствуют типу стены, покупатель должен в обязательном порядке приобрести соответствующие дюбели в специализированном магазине.

EL

Οι πλαστικές βύδες που παρέχονται προορίζονται για ενσωμάτωση σε συνθησμένο τοίχο από τούβλα. Πριν από την ενσωμάτωση, ο χρήστης οφείλει να ελέγξει εάν οι βύδες που παρέχονται αντιστοιχούν στον τύπο του τοίχου στον οποίο προβλέπεται η ενσωμάτωση. Εάν οι βύδες δεν ταιριάζουν στον τοίχο, ο αγοραστής υποχρεούται να προμηθευθεί κατάλληλες σε εξειδικευμένο κατάστημα.

BG

Доставените пластмасови дюбели са направени за вграждане в стандартна тухлена стена. Преди вграждането, ползувателят е длъжен да провери дали доставените дюбели съответстват на стената, за която са предвидени за вграждане. Ако дюбелите не съответстват на стената на купувача, то той задължително трябва да закупи съответни дюбели от специализиран магазин.

SL

Dostavljeni plastični nosilci so namenjeni za montažo na standardni zid iz opeke. Pred montažo je uporabnik dolžan preveriti, ali dostavljeni nosilci ustrezajo vrsti zidu, na katerem je predvidena montaža. V kolikor nosilci niso primerni, je kupec dolžan sam pri specializiranemu prodajalcu priskrbeti nosilce, ki ustrezajo montaži.

MK

Доставените пластични типли наменети се за прикачување на стандарден зид од цигла. Пред прикачувањето корисникот е должен да провери дали доставените типли одговараат на видот на зидот на кој е предвидено прикачувањето. Доколку типлите не одговараат купувачот е должен сам да набави во специјализирана продавница типли кои одговараат.

PL

Dołączone plastikowe kołki są przeznaczone do montażu na standardową ścianę z cegły. Przed zamontowaniem, użytkownik jest zobowiązany upewnić się, czy załączone kołki odpowiadają typowi ściany na której jest przewidziany montaż. W przypadku gdy kołki nie są odpowiednie do typu ściany, na którą ma być zamontowany regał, użytkownik jest zobowiązany, aby samemu zaopatrzyć się w odpowiedni typ kołków w sklepie specjalistycznym.

**UK**

Delivered plastic plugs are intended for fitting on a standard brick wall. Before fitting, the buyer needs to check if the delivered plugs are suitable for the wall they are foreseen for. If the plugs are not suitable for the wall, buyers have to visit a specialized store and get suitable plugs by themselves.

IT CH

I tasselli di plastica consegnati sono destinati al montaggio su un muro di mattoni standard. Prima del loro montaggio, l'acquirente deve controllare se i tasselli forniti sono adatti per la parete su cui si prevede di installarli. Se i tasselli non sono adatti per questo tipo di parete, l'acquirente è tenuto ad acquistare i tasselli adeguati presso un negozio specializzato.

FR CH

Les chevilles en plastique fournies sont conçues à l'installation sur le mur standard en briques. Avant l'installation, l'utilisateur est obligé de vérifier si les chevilles fournies correspondent bien au type de mur prévu pour l'installation. Si les chevilles ne correspondent pas bien au mur, l'acheteur est obligé d'assurer lui-même les chevilles correspondantes dans un magasin spécialisé.

CZ SK

Dodané plastové hmoždinky jsou určeny pro montáž na standardní cihlovou stěnu. Před začátkem montáže, kupující je povinnen dohlédnout na správnost typu dodaných hmoždinek, vzhledem na typ stěny určené k montáži. Pokud hmoždinky dodané výrobcem neodpovídají typu stěny určené k montáži, kupující je povinnen pořídit si správný typ ve specializované prodejně.

RO

Tiplurile din plastic transmise sunt prevăzute exclusiv pentru pereții standard din cărămidă. Înainte de instalare beneficiarul este obligat să verifice dacă tiplurile transmise corespund peretelui pe care se prevede instalarea. În cazul în care tiplurile nu corespund peretelui, cumpărătorul este obligat să achiziționeze singur tiplurile corespunzătoare din magazinele specializate.

HR BIH

Dostavljeni plastični tiplovi su namijenjeni za ugradnju na standardan zid od cigle. Prije ugradnje korisnik je dužan da provjeri da li dostavljeni tiplovi odgovaraju vrsti zida na koji je predviđena ugradnja. Ukoliko tiplovi ne odgovaraju zidu kupac je u obavezi da u specijaliziranoj radnji sam nabavi odgovarajuće tiplove.

HU

A kézbesített műanyag tiplik standard téglafalra való beépítésre szolgálnak. Beépítés előtt a felhasználónak köteles leellenőrizni, hogy a tiplik megfelelőek-e a falajtájának, amelyre a beépítést szánták. Ha a tiplik nem felelnek meg, a vásárló köteles a megfelelőket szaküzletben beszerezni.

AL

Ankorat e dhëna plastike janë të dizajnuara për instalim në mur standard me tulla. Para instalimit përdoruesi duhet të verifikojë nëse ankorat e dërguara iu përshtaten llojit të murit në të cilin është parashikuar të bëhet instalimi. Nëse ankorat nuk iu përshtaten murit, blerësi është i obliguar që vetë të blejë ankorat e duhura në shitoren e specializuar.